

Sermons You Can Preach

By

Leroy Brownlow

BROWNLOW PUBLISHING COMPANY, INC.

P. O. Box 3141

FORT WORTH, TEXAS 76105

Copyright, 1958

By Leroy Brownlow

Every portion of this book may be used freely in oral form. But all publishing rights are reserved. No sermon or portion of a sermon may be reprinted without written permission of the publisher.

FOREWORD

The very generous reception which has been and continues to be accorded *Seed for the Sower* and *The Greatest Questions of the Ages*, together with countless numbers of testimonies, has encouraged the author to send forth another volume in the field of sermon making.

This volume contains one hundred sermons which have been preached in the pulpit of the Polytechnic Church of Christ, Fort Worth, Texas, where the author at this date, 1957, has preached for fourteen consecutive years. These sermons are practical rather than theoretical. They are simple and usable.

As far as the author knows, these sermons are original. Of course, neither every thought nor every title is original, but the sermons are.

Scripture quotations are from the King James Version, because it is used more by the masses than any other translation.

Some of these sermons are brief outlines, while others are more fully developed. Such meets the needs of more workers. Young and inexperienced workers need considerable material, while others need only a thought.

The style of writing used in this volume is aimed at both brevity and clarity.

The hope is now entertained that these sermon notes may be of some help to many who teach the Bible in any capacity, and that they may also encourage many others to commence telling the Glad Story. May every page be a challenge to deeper thought and more extensive study.

LERROY BROWNLOW

Fort Worth, Texas, U. S. A.

CONTENTS

Sermon	Page
1. "THE WORD OF THE LORD IS RIGHT"	7
2. OUR MISUNDERSTOOD BIBLE	9
3. "YE DO ERR NOT KNOWING THE SCRIPTURES"	11
4. GOD'S PLAN AS SIMPLE AS ONE, TWO, THREE	12
5. THE ETERNAL PRINCIPLES OF GOD IN DEALING WITH MAN	13
6. MEN DISPLEASED WITH GOD	14
7. MAN'S NEED OF SALVATION	16
8. WHY MANY PEOPLE ARE NOT SAVED	18
9. WHY MANY PEOPLE ARE NOT SAVED (continued)	19
10. FALSE IDEAS OF GOD	19
11. "PREPARE TO MEET THY GOD"	21
12. THE CROSS-CENTERED RELIGION	22
13. CAUSE AND EFFECT	24
14. NOTHING	24
15. GOD IS GOOD	26
16. "HE WENT AWAY SORROWFUL"	27
17. CHRISTIAN	28
18. GOSPEL	29
19. A GOOD MAN'S FALL AND RETURN	29
20. WHAT IS DEATH?	32
21. "I WILL . . . BEFORE I DIE"	33
22. MAN MAY DO SEVERAL THINGS AND STILL BE LOST ..	34
23. PREACHING ON THE ROSTRUM	35
24. BACKSLIDING	37
25. WORDS AGAINST THE LORD	38
26. MIND YOUR OWN BUSINESS	40
27. GREAT DECISIONS OF THE BIBLE	41
28. PRICES WE PAY	43
29. YOU AND YOUR BROTHER	44
30. "KEEP THYSELF"	46
31. "WHEN THE ROLL IS CALLED UP YONDER"	47
32. THE ROLL UP YONDER	48
33. RETURNING GOOD FOR EVIL	50
34. "LOOK WHAT YOU MADE ME DO"	51
35. REASONS FOR DOING MISSIONARY WORK	53
36. ARE YOU READY?	54
37. MISTAKES OF "SUCCESSFUL" MEN	56
38. LOST RELIGIOUS PEOPLE	58
39. SOME THINGS FOR CHRISTIANS TO REMEMBER	59
40. QUESTIONING THE CONVENTIONAL	61
41. ONWARD CHRISTIAN SOLDIERS	62
42. "IF ANY MAN WILL COME AFTER ME"	64
43. WHAT ABOUT REINCARNATION?	66
44. ALMOST	67
45. TOMORROW	68
46. WHAT AN HONOR TO BE CALLED "CHICKEN"	70
47. "NOTS" WHICH CANNOT BE UNTIED	71

Sermon	Page
48. WORSHIP	73
49. "GIVE US SOMETHING PRACTICAL"	75
50. "HANDLE WITH CARE"	76
51. "THOU SHALT BE MISSED"	78
52. SAINTS IN WRONG PLACES	81
53. NEGLECTED AND REJECTED OPPORTUNITIES	82
54. JOHN THE BAPTIST	83
55. AT THE OPENING GATES OF THE NEW YEAR	84
56. ARE WE GOING TO TAKE THE BACKBONE OUT OF THE CHURCH OF CHRIST?	86
57. FREEDOM FROM YOUR SELF-PRISONS	87
58. "I AM A DEBTOR"	89
59. SPIRITUAL AILMENTS	90
60. THE PROOF OF TIMOTHY	92
61. "IT IS BETTER"	93
62. KINDS OF FOLLOWERS OF CHRIST	95
63. YOU ARE THE ANSWER TO THE QUESTION	97
64. JUDAS ISCARIOT	98
65. WHAT DOES IT MEAN TO RECEIVE THE WORD?	100
66. SELF	101
67. PUTTING AWAY CHILDISH THINGS	103
68. THE BIBLE IS A BOOK ON GIVING	104
69. THE PRAYER OF EXAMPLE	105
70. THE CHRISTIAN LIFE	107
71. A REJECTION OF THE COUNSEL OF GOD	109
72. NOT EVERYONE	110
73. SOME EVILS CHRIST SAW IN THE LIVES OF THE PEOPLE	111
74. "TAKE IT EASY"	113
75. IF	115
76. "LET NO MAN-DECEIVE HIMSELF"	116
77. SIN	118
78. THE SAYINGS OF SATAN	119
79. ONE	120
80. TWO	121
81. THREE	122
82. FOUR	122
83. FIVE	123
84. SIX	124
85. SEVEN	124
86. GOOD PEOPLE	125
87. GOOD PEOPLE	127
88. IS THE DEVIL A FOOL?	128
89. ARE WE FOOLS?	129
90. THE VALUE OF THE BIBLE	130
91. THE VALUE OF THE SOUL	131
92. THE VALUE OF THE LOCAL CHURCH	132
93. THE VALUE OF INFLUENCE	133
94. THE VALUE OF THE DOLLAR	134
95. "WHO WENT ABOUT DOING GOOD"	135
96. WHY THE CHURCH GREW SO FAST IN THE FIRST CENTURY	137
97. CHRISTIAN IN DISPOSITION	138
98. IS ONE CHURCH AS GOOD AS ANOTHER?	139
99. HOW TO FIGHT SATAN	141
100. THE WAY HOME	142

“THE WORD OF THE LORD IS RIGHT”

Psa. 33:4

1. *Introduction.* (1) We are living in an age of disbelief. Modernism, a new word for infidelity, is on the increase. (2) “But the word of the Lord is right.” The evidence is certain.

2. The Bible is right because *it offers the only possible explanation of creation* (Gen. 1:1). (1) The evolutionist has no explanation, because he has to start with something and does not know how to get that something. (2) The Bible begins with God, a self-existent being (Gen. 1:1).

A. Something cannot come from nothing.

B. But something is (exists).

C. Therefore, something always was

I challenge the atheist to name that something from which everything else has come. (3) I challenge the atheist to account for life without a Supreme Life. Jordan and Kellogg, in their book, *Evolution and Animal Life*, p. 41, make this statement: “All life comes from life. The biologist cannot admit spontaneous generation in the face of the scientific evidence he has.”

3. *Geology proves the Bible is right.* (1) “And the earth was without form and void” (Gen. 1:2). Science says that this is right, that the earth was waste at that time and that there was no vegetable or animal life upon it. (2) “God moved upon the face of the waters” (Gen. 1:2). Science says that ice and water covered the entire earth. Geology calls this period the great ice age. (3) “And God said, Let there be a firmament in the midst of the waters, and let it divide the waters from the waters” (Gen. 1:6). Science says that we have two major bodies of water, one on the earth and the other in the heavens. Moses says that the firmament was established to separate the waters above from the waters below.

4. *Archaeology corroborates the Bible.* (1) Ex. 1:11 has been confirmed. A recent discovery of an inscription says that Ramses II built the city of Raamses with Jewish labor.—*Bible vs. Modernism*, Trice and Roberson, p. 132. (2) Ex. 5—making brick without straw—has been proven. The ruins of granaries in Pythom and Raamses reveal that in the lower courses the brick were made with straw, while in the upper portions they contained no straw.—*Bible vs. Modernism*, Trice and Roberson, p. 132. (3) Nothing has been unearthed that contradicts the Bible.

5. *Astronomy confirms the Bible.* (1) No scientist can give a better description of the earth than that given in Job 26:7: "He stretcheth out the north over the empty place, and hangeth the earth upon nothing." (2) "It is he that sitteth upon the circle of the earth" (Isa. 40:22) — not flatness. (3) Jesus will come in the day and in the night (Lk. 17:31, 34) — earth is round and there is day on one part when there is night on the other part.

6. *History confirms the Bible.* Josephus, who lived from about 37 A. D. to about 100 A. D., said of Christ: "And when Pilate, at the suggestion of the principal men amongst us, had condemned him to the cross . . . he appeared to them alive again the third day . . ." — Book 18, Chapter 3.

7. *Martyrdom sustains the truth of the Bible.* (1) Writers of the New Testament had been with Christ (I Jno. 1:1). (2) Their testimony brought them no physical or temporal gain. It meant the loss of friends, home, and an easy life; it meant persecution and death. If the Bible is not true, then there is no sincerity in martyrdom.

8. *Prophecy substantiates the Bible as true.* (1) Isa. 7:13,14 — Lk. 1:26-35. (2) Mic. 5:2 — Matt. 2:1-11. (3) Isa. 40:3; Mal. 3:1,2 — Jno. 1:22,23; Mk. 1:1-7. (4) Zech. 9:9,10 — Matt. 21:1-9. (5) Psa. 41:9 — Mk. 14:43-49. (6) Zech 11:12,13 — Matt. 27:3-10. (7) Psa. 22:18 — Jno. 19:23,24. (8) We have seen I Tim. 4:1-3 and II Thess. 2:3,4 fulfilled in the Roman Church.

9. *The manner in which the Bible was written is evi-*

dence that it is divine. It was written by about forty writers during intervals of about sixteen centuries. They wrote independently of each other; they could not have conspired to write a fraud. But their works made one complete volume of harmony and continuity of thought. It could not be an accident.

OUR MISUNDERSTOOD BIBLE

1. *Introduction.* The Bible is the world's most popular book, the world's most influential book; yet it is the world's most misunderstood book.

2. *Many people misunderstand the whole Bible.* (1) They misunderstand its source; they think it is a human book poked off on the world as a pious fraud. But the Bible is the inspired message of God (II Tim. 3:16,17; II Pet. 1:21). (2) Some misunderstand the purpose of the Bible; they think it is a fable. But it is here to furnish man unto every good work (II Tim. 3:16,17). This is reasonable; because if there is a God — and there is — then it is reasonable that he would give man a message of guidance and hope. (3) Some misunderstand its indestructibility; hence, many have vainly sought to destroy it. But if every Bible should be destroyed, it could be reproduced easily from the thousands of other books which quote it. And if this were not possible, it still would not be destroyed. It would still appear at the judgment to face us (Mk. 13:31; Jno. 12:48; Rev. 20:12).

3. *Many people misunderstand the Testaments — Old and New.* (1) Consequently, they are just as apt to go to Psalms as to Acts to find the plan of salvation. This error is the father of many other errors. (2) We are now living under the reign and rule of the New Testament. The law of Moses was to last until Christ came (Gal. 3:19). Jesus nailed it to the cross (Col. 2:14). Today we must hear Christ (Matt. 17:15; Heb. 1:1,2). The first covenant was taken away that we might have the second (Heb. 10:9).

4. Many people misunderstand the books of the Bible.

(1) The Old Testament books point forward to Christ's coming (Gen. 3:15; Isa. 53). The Mosaic law was a schoolmaster to prepare man for Christ (Gal. 3:24). (2) The New Testament books point backward to Christ's having come. The gospels are books of evidence to create faith in Christ (Jno. 20:30,31). Acts is the book of conversions. The epistles to individuals and churches were written especially to instruct Christians. In Revelation man was given a glimpse of things to come.

5. Many people misunderstand the chapters of the Bible. (1) They think it came from God, broken down in chapters. But man arranged it in chapters. (2) The break for chapters often contributes to misunderstanding, because it breaks the thought. For instance, some think the baptism of Holy Spirit came upon the 120 (Acts 1); but if you read Acts 1:26 along with Acts 2 as if there were no chapter break, you will see that the apostles were the ones baptized with Holy Spirit (Acts 2:1-13).

6. Many people misunderstand the verses of the Bible.

(1) They are not aware of the fact that the Bible was broken down into verses by man. (2) They expect too much from one verse; they expect to get the whole plan of salvation from one verse. But there is no one verse in the Bible that gives the whole plan of salvation. We must take the whole counsel of God (Acts 20:27), all Scripture (II Tim. 3:16,17).

7. Many people misunderstand the phrases of the Bible. (1) They misunderstand such simple phrases as, "He that believeth and is baptized shall be saved" (Mk. 16:16). They try to get salvation before baptism. (2) And they misunderstand Acts 2:38, "Repent, and be baptized every one of you in the name of Jesus Christ for the remission of sins." They try to get to the remission of sins before baptism. But repentance and baptism are joined together by the copulative conjunction "and" — a conjunction which couples words and phrases — and points to the same object which is the remission of sins. So repentance and

baptism are for the same purpose. Also, some misunderstand "for" in the verse. They say it means "because of" — be baptized because of remission of sins. However, it means in Acts 2:38 what it means in Matt. 26:28: ". . . blood . . . shed . . . for remission of sins" — not that Jesus shed his blood because our sins were already remitted.

8. *Many people misunderstand the words of the Bible: repentance, baptism, etc.* (1) Repentance means more than reformation (Matt. 3:8); it is also related to godly sorrow for sin (II Cor. 7:10). (2) The dictionary defines baptism as sprinkling, pouring, and immersion; because the function of a dictionary is to give the usages of a word. But this has no bearing on the original and scriptural meaning of the word, which is to dip or immerse (Jno. 3:23; Rom. 6:3,4; Acts 8:36-39).

"YE DO ERR NOT KNOWING THE SCRIPTURES"

Matt. 22:29

1. *Text implies that the Scriptures are the standard of life.* (1) II Tim. 3:16,17; II Pet. 1:3; Psa. 119:105. (2) Man needs this standard (Jer. 10:23) — just like he needs standards of time, weights, and measures.

2. *Text implies that we err if we deviate from the Scriptures.* (1) Deut. 4:2; Rev. 22:18,19. (2) Moses smote rock — erred by going beyond (Num. 20:7-11). (3) Saul saved Agag and the best of the sheep and oxen — erred by falling short (1 Sam. 15:1-23).

3. *The people in the context erred because they knew not the Scriptures.* (1) They erred "not knowing." If they had known the O. T. Scriptures, they would have known a number of passages teaching the resurrection: Dan. 12:2; Job 19:25,26; Psa. 16:10; 23:6. (2) They erred "not knowing . . . the power of God" (Matt. 22:29). When once the omnipotence of God is recognized, it is easy to believe in his power to perform any supernatural

work. Acts 26:8. (3) They further erred not knowing that there will be a different type of life in the resurrected state (Matt. 22:30). (4) The source of their error was ignorance. True of many. Acts 3:17; I Cor. 2:8. (5) One of the biggest delusions of the day is a dependence upon human reason for guidance instead of the Scriptures (I Cor. 1:18,19,25; 2:5). (6) Man must know the truth (Jno. 8:32; 5:39).

4. *Some others who know the Scriptures also err.* It is not for ignorance. It is for other reasons; for instance: (1) Want their own will. True of rich young ruler (Matt. 19:16-22) and Jonah. Lady said, "How can we be Christians and have our own way?" Matt. 6:10; 26:39. (2) Prejudice (Acts 7:54-60; Matt. 13:15). (3) Preconceived ideas cause some to color the Scriptures. The Jews were unable to understand the Great Commission (Mk. 16:15, 16). It took a miracle to get them to understand that it also applied to the Gentiles (Acts 10, 11). (4) Know only a fragment of Scriptures. Must take the whole counsel of God (Acts 20:27), all Scripture (II Tim. 3:16,17).

GOD'S PLAN AS SIMPLE AS ONE, TWO, THREE

1. *One.* (1) One God (Eph 4:4). A. He is a self-existent being (Psa. 90:2). B. Creator (Gen. 1:1). C. This One is all we need — should have no other gods (Ex. 20:3). (2) One man was created (Gen. 1:27; 2:7). A. One woman was created from man (Gen. 2:22,23). B. From this couple has come all nations (Acts 17:26). C. By "one man sin entered into the world" (Rom. 5:12; Gen. 3:1-6). (3) One Lord (Eph. 4:5). Came as man's redeemer (Gen. 3:15; Heb. 10:4; Matt. 1:21; Eph. 1:7). (4) One Spirit (Eph. 4:4). It was necessary for the one Spirit to come and carry on the work that Jesus had begun (Jno. 14:26; 15:26; 16:13). (5) One faith was given for man to embrace (Eph. 4:5). One gospel (Rom. 1:16; Gal. 1:8,9). One way (Jno. 14:6). (6) One baptism was given for man to obey (Mk. 16:15,16; Rom. 6:3,4). (7, One body

was founded to which man may be added (Eph. 4:4; 1:22,23; Matt. 16:18; Acts 2:47). (8) One hope (Eph. 4:4). Heb. 6:19.

2. *Two.* (1) Man is two in one, a dual being (Eccl. 12:7; II Cor. 4:16; 5:1; Jas. 2:26). (2) God's plan calls for two births, physical and spiritual (Jno. 3:3-5). (3) Bible speaks of two deaths, physical and spiritual (IIeb. 9:27; Rev. 20:14,15). He who is born twice and is faithful will die but once (Jno. 8:51; Rev. 2:11), while he who is born only once will die twice.

3. *Three.* The work of three beings is very important in the divine plan. (1) God, the designer, creator, and benefactor (Gen. 1:1; Jas. 1:27). (2) Christ, the redeemer, lawgiver, and example (Eph. 1:7; Heb. 1:1,2; I Pet. 2:21). (3) Holy Spirit, the comforter, teacher, and guider (Jno. 14:26; 15:26; 16:13).

THE ETERNAL PRINCIPLES OF GOD IN DEALING WITH MAN

1. *Introduction.* (1) Three eternal principles characterize God's dealings with man in every age: grace, faith, obedience. (2) This is true in all three dispensations.

Patriarchal	Jewish	Christian
Grace	Grace	Grace
Faith	Faith	Faith
Obedience	Obedience	Obedience

2. *Examples under patriarchal law.* (1) Adam and Eve. They were created in the image of God (Gen. 1:27), placed in Garden (Gen. 2:8), and given a law (Gen. 2:16,17) — acts of grace. They had to believe and obey God (Gen. 3:1-6, 22-24) — faith and obedience. (2) Noah. Grace was extended to him (Gen. 6:8). He had to believe

(Heb. 11:7). He had to obey (Gen. 6:22). (3) Abraham. Great promises came to him through grace. He had to believe (Heb. 11:17-19) and obey (Gen. 22:1-14).

3. *Examples under the Jewish law.* (1) Deliverance of the children of Israel (Ex. 3:8-10). It was an act of God's grace. Moses had to believe God and obey. (2) Looking on brazen serpent (Num. 21:8,9). God's grace provided the plan. The people had to believe and obey. (3) Naaman (II Kings 5). God, through Elisha, provided the cure — an act of grace (II Kings 5:10). Naaman had to believe and obey (II Kings 5:11).

4. *Examples under the Christian dispensation.* God's grace has come in the form of teaching (Tit. 2:11). God's word is "the word of his grace" (Acts 20:32). Hence, God's grace can be received in vain (II Cor. 6:1). (1) People on Pentecost (Acts 2). Grace was extended to them; they were not worthy; they were murderers. They believed (Acts 2:37) and obeyed (Acts 2:41). (2) Eunuch (Acts 8). It was grace that caused the Lord to send Philip to preach to him (Acts 8:26). He believed and obeyed (Acts 8:37,38). (3) Paul. Grace was bestowed upon him (I Cor. 15:10). He believed (Acts 9:6) and obeyed (Acts 26:19; 22:16; 9:18).

MEN DISPLEASED WITH GOD

1. *Introduction.* This is a basic evil in the land.

2. *Naaman* was displeased with God's command (II Kings 5:1-14). (1) He was a great and honorable man (ver. 1) — many good men have been displeased with God. (2) He wished to follow his own human opinion — "Behold, I thought . . ." (ver. 11). (3) He wondered why a substitute would not do as well as the thing God commanded (ver. 12). (4) Many are like Naaman, displeased with God; wish to follow opinions and substitutes.

3. *Rich young ruler* was displeased with the Lord because he was not permitted to keep his idol (Matt. 19:16-22). (1) Covetousness is idolatry (Col. 3:5). (2)

He wanted riches first and salvation second; but salvation must be first (Matt. 6:33). (3) He wanted to trust in riches first and the Lord second; but trust in the Lord comes first (Prov. 3:5; I Tim. 6:17).

4. *The men who crucified Jesus* were so displeased with him that they took his life (Matt. 27). Some people today are unhappy with Jesus and crucify him afresh (Heb. 6:6). Hymn: "Shall I Crucify My Savior?"

5. *Many special groups today* are displeased with God. (1) Atheists are displeased with the thought of God (Gen. 1:1). (2) Modernists are displeased with the inspiration of the Scriptures (II Tim. 3:16,17; II Pet. 1:21). (3) Roman Catholic Church is displeased with the completeness of the Bible (Jude 3; Rev. 22:18,19). They want the voice of the church to be as authoritative as the Bible; that way they find consolation in having what they wish, even though it is not mentioned in the Bible. (4) Protestant denominations are displeased with the Biblical teachings on unity, one body, one faith, and one baptism (Eph. 4:3-6).

6. *Other examples.* (1) Churches which have women preachers are displeased with this verse in the Bible: "Let your women keep silence in the churches: for it is not permitted unto them to speak . . ." (I Cor. 14:34). (2) Churches which vote on people for church membership are unhappy with Acts 2:47, which states that God does the adding. We now quote:

It is most likely that in the Apostolic age when there was but "one Lord, one faith, and one baptism," and no differing denominations existed, the baptism of a convert by that very act constituted him a member of the church, and at once endowed him with all the rights and privileges of full membership. In that sense, "baptism was the door into the church." Now, it is different; and while the churches are desirous of receiving members, they are wary and cautious that they do not receive unworthy persons. The churches therefore have candidates come before them, make their statement, give their "experience," and then their reception is decided by a vote of the members.

—The Standard Manual for Baptist Churches, Edward T. Hiscox, p. 22.

“Now, it is different!” Well, why is it different? And by what authority was it made different? No! God’s word does not change (Matt. 24:35). (3) Churches which practice infant baptism are dissatisfied with Matt. 28:19, Mk. 16:16, and Acts 2:38 which put teaching, faith, and repentance before baptism. (4) Churches which take up offerings everytime they meet are displeased with God’s command to give on the first day of the week (1 Cor. 16:2). (5) Martin Luther was so displeased with Rom. 5:1 — “Therefore being justified by faith” — that he wrote “only” between the lines. But his wishing did not change it. His interpretation contradicts Jas. 2:24. (6) In the second century men became so displeased with God’s government for the church — a plurality of bishops or elders in one church (Acts 20:17,28) — that they began to have one bishop in one church. The system of episcopacy and papacy continued to develop and finally in 606 A. D. they had their first fully developed pope, Boniface III. (7) Some are so displeased with being guided by what the Bible says (II Tim. 3:16,17) that they rather wish to be guided by what it does not say. Thus, they say, “The Bible doesn’t say not to do so and so.”

7. *God knew that some people would become displeased with the divine order and would wish to change it.* (1) So he commanded man not to change it (Deut. 4:2; Gal. 1:8,9; Rev. 22:18,19). (2) Jesus taught us to pray that God’s will be done (Matt. 6:10).

MAN’S NEED OF SALVATION

1. Man needs salvation *because of sin.* Gen. 3; Rom. 3:23; I Jno. 1:10; Isa. 59:2; Ezek. 18:20; Gal. 6:7,8.

2. Man needs salvation *because he is a man and not an animal.* (1) No animal needs salvation. (2) Man is physical and spiritual (Gen. 35:18; II Cor. 4:16; Eccl.

12:7). (3) There is a part of man that cannot be satisfied with bread alone (Matt. 4:4). The rich fool made the mistake of thinking that his soul could live on material things (Lk. 12:15-21).

3. The history of the world is but *a history of man's need of salvation*. (1) The downfall of man (Gen. 3). (2) The separation of a race, Abraham's descendants (Gal. 3:16-19). (3) Animal sacrifices testified to this need — "a remembrance of sins year by year" (Heb. 10:1-4). (4) Birth of Christ (Matt. 1:21). (5) Christ on the cross (I Cor. 15:3). (6) Christ's resurrection (Rom. 4:25).

4. Man needs salvation *because he needs help now*. (1) Needs guidance (Jer. 10:23). (2) Needs happiness (Psa. 144:15; Acts 8:39). (3) Needs an example (I Pet. 2:21). Illustration: Hawthorne's story of "The Great Stone Face." On the side of the mountain there was a clear-cut face. It was said that some day a man resembling the stone face would come to the village. He would be the people's greatest friend. A boy studied the face of every stranger to see if he might be the one. The years passed, and the boy held to the hope that some day the man with the stone face would come. As the thought lingered in the boy's mind, he was led to idealize the character of the man who should come: lofty in thoughts, strong in faith, gentle in manners, pure in character, and brave in convictions. The years went by. His hair whitened and his face took on more and more the expressions of his ideal. Then the people came to realize that he was the benefactor and counselor of them all, the very image of the stone face. We become like our ideals (Rom. 12:2).

5. Man needs salvation *because he, as a rational being, must account to God*. (1) II Cor. 5:10; Rom. 2:6; Matt. 25:32. (2) Man should make preparation (Amos 4:12). He should have the sense of an ant (Prov. 30:25).

6. Man needs salvation *because he must spend eternity somewhere*. (1) In heaven (Jno. 14:1-4; Rev. 21). (2) Or in hell (Matt. 10:28; Rev. 20:14,15).

7. Man's need of salvation is *seen in the Great Commission*. Matt. 28:19,20; Mk. 16:15,16.

WHY MANY PEOPLE ARE NOT SAVED

1. *Many are lost* (Matt. 7:13,14). Why? Different individuals are lost for different reasons, as follows:

2. Because they *do not think they are lost*. Believe in almost universal salvation — think they are too good to be lost. The man who thinks he is safe will not make any effort to get to safety.

3. Because they *do not believe*. (1) Satan has stolen the word from them (Lk. 8:12). (2) No hope for the disbeliever (Mk. 16:16; Heb. 11:6; Jno. 8:24).

4. Because they are *trusting in faith only*. (1) Jas. 2:24,26. (2) Noah was saved by an obedient faith (Heb. 11:7). (3) Obedience is necessary (Matt. 7:21; Heb. 5:8,9).

5. Because they *love sin*. Jno. 3:19; II Tim. 3:1-5; I Jno. 2:15-17.

6. Because they are *trusting in morality*. If morality would save, man could be saved apart from Christ (Matt. 1:21), Christ's blood (Eph. 1:7), faith (Heb. 11:6), obedience (Heb. 5:9), and Christ's church (Eph. 5:23).

7. Because they *love human praise*. True of the rulers (Jno. 12:42,43).

8. Because they are *biased*. It has closed their eyes and stopped their ears (Matt. 13:15). Acts 7:57.

9. Because, not loving the truth, they have been *blinded*. II Thess. 2:10-12; II Cor. 4:4; Matt. 15:14.

10. Because they became *unfaithful*. (1) Failed to add Christian graces (II Pet. 1:5-10). (2) Failed to bear fruit (Jno. 15:1-6). (3) The last state is worse than the first (II Pet. 2:20-22).

WHY MANY PEOPLE ARE NOT SAVED—Continued

1. *Introduction.* Matt. 7:13,14; 22:14.

2. Because of *secret skepticism*. Do not believe the Bible — want to believe it in spots.

3. Because they *will not read and investigate the Bible*. Jno. 5:39; Acts 17:11.

4. Because they *want to be their own god*. (1) Want to make their own laws (Jer. 10:23). (2) Want to be saved according to their own terms instead of the Lord's. Jno. 5:30; Matt. 6:10; Lk. 22:42.

5. Because they are *trusting in feelings to assure them of salvation*. Prov. 14:12; Acts 26:9; 23:1; I Jno. 2:3.

6. Because they *will not give up the religion of their parents*. Matt. 8:21,22; 10:37.

7. Because they *have become hardened*. Their hearts are like wayside soil (Matt. 13:3,4,18,19).

8. Because they *will not repent*. Lk. 13:3; Acts 17:30. This is the hardest thing in the plan of salvation.

9. Because of *neglect*. Heb. 2:3. Procrastination is dangerous (Acts 24:25).

FALSE IDEAS OF GOD

Acts 17:23

1. *Some think God's power is limited to evolution*. This is inconsistent, for the same God who could create anything could create everything. Gen. 1:1.

2. *Some think God is an American God* — think Americans are God's chosen people. (1) "Hath made of one blood all nations" (Acts 17:26). (2) God loves the whole world (Jno. 3:16). (3) Jesus tasted death for every man (Heb. 2:9). (4) He will judge the whole world (Acts 17:31).

3. *Some think God is physical*. (1) He is not the material creation many have thought. (2) "God is a Spirit" (Jno. 4:23,24). "A spirit hath not flesh and bones" (Lk. 24:39). (3) The fact that you cannot see a spirit does not

mean that it does not exist. Neither can you see electricity nor pain.

4. *Some think God is local.* (1) He cannot be confined to temples (Acts 17:24) or to localities (Psa. 139:7-10). (2) If man can be in spirit several places at the same time, then how easy it is for God who is a Spirit to be every place at the same time.

5. *Some think God created man and then left him on earth without any instructions.* (1) This would be unreasonable. (2) The Bible is the most reasonable thing in the world (II Tim. 3:16,17).

6. *Some think God is afar off* — far off in space. (1) "Though he be not far from every one of us: for in him we live, and move, and have our being" (Acts 17:27,28). (2) He is so little he can dwell in my heart and so big that he can be every place.

7. *Some think God is a God of confusion,* that he has called one man to deny what he has called another to affirm. (1) "God is not the author of confusion" (I Cor. 14:33). (2) He gave one body, one faith, and one baptism (Eph. 4:4,5). (3) Phil. 3:16.

8. *Some think God is reluctant to save.* (1) This misconception gave rise to the mourner's bench system of religion. (2) Do not have to plead with God to save (I Tim. 2:3,4; II Pet. 3:9). (3) Have to plead with man to be saved (Acts 2:40).

9. *Some think God is too good to condemn.* (1) But he is too good to condone sin (Isa. 59:2; Jno. 8:21). (2) God has done his part to save us (Jno. 3:16; Rom. 5:8). (3) Man condemns himself (Acts 13:46).

10. *Some think God is like man* (Psa. 50:21). (1) Man hides from man; so he thinks he can hide from God (Gen. 3:8). (2) Man deceives man; so he thinks he can deceive God (Acts 5:1-10). (3) Man thinks one religion is as good as another; so he thinks God feels this way, but he does not (Matt. 15:9,13,14).

“PREPARE TO MEET THY GOD”

Amos 4:12

1. *God is.* (1) The fact that you cannot see him does not prove that he does not exist. Cannot see pain, electricity, hope, sorrow. (2) The only way to account for things is to begin with a self-existent being (Gen. 1:1). Evolution accounts for nothing. The atheist reminds me of the story of a dog on an express car. Some one asked the expressman: “Where does this dog go?” He replied, “I don’t know; he don’t know; nobody don’t know; because he has gone and chawed up his tag.” According to atheism, nobody knows where we came from, why we are here, or where we are going. (3) Nature testifies to God (Psa. 19:1). This world could not have just happened. It has been calculated that if the 26 letters of the alphabet were tossed into the air by chance force, they might fall together in the present order — A, B, C, etc. — once in 500 million, million, million times. But there is more order than this in the universe. To argue that the world is the work of blind chance is as unreasonable as to argue that the Fort Worth telephone directory is the result of an explosion in a printing factory. (4) The Bible testifies to God. Gen. 1:1; Eccl. 12:1,7; Acts 17:24. (5) An atheist does not know there is no God unless he knows everything. If there is one thing he does not know, it might be the fact there is a God. And if man knows everything, then he is a god himself.

2. *Man must meet God* — judgment. (1) Justice demands the judgment. It would be unjust for the good and the evil to be awarded alike. (2) Man has courts because he sees the need of judgment. (3) Our meeting God will be universal — no exceptions. Everyone (Rom. 14:12). All persons (Rom. 14:10), all nations (Matt. 25:32), and all the world (Acts 17:30,31) will be there. (4) The Bible will be the standard of judgment (Jno. 12:48; Rev. 20:12). (5) Each must meet God on his own record (Rom. 14:12; II Cor. 5:10; Gal. 6:7). (6) The

meeting will be at an hour when we think not (Matt. 24:36; II Pet. 3:10; Matt. 24:42-44).

3. *Should prepare for the occasion.* (1) Too much is involved not to prepare for it (Mk. 8:36,37; Matt. 10:28). (2) Life is too uncertain not to prepare now (Jas. 4:13,14; Heb. 3:8,15; 4:7). (3) How prepare? Search Scriptures (Jno. 5:39). Be doers of word and not hearers only (Jas. 1:22). Obey gospel (Rom. 1:16). Add Christian graces (II Pet. 1:5-10). Persevere (Matt. 10:22). (4) The greatest tragedy is to fail to make preparation. This was the tragedy of the foolish virgins and the one-talent man (Matt. 25:1-13,14-30).

4. *The outcome of the meeting* (Matt. 25:31-46). (1) This is the day for which man lives (Eccl. 12:13). (2) If man fails here, he fails in his whole duty (Eccl. 12:13).

THE CROSS-CENTERED RELIGION

1. *Introduction.* Christianity centers around the cross. The hymn: "The Old Rugged Cross."

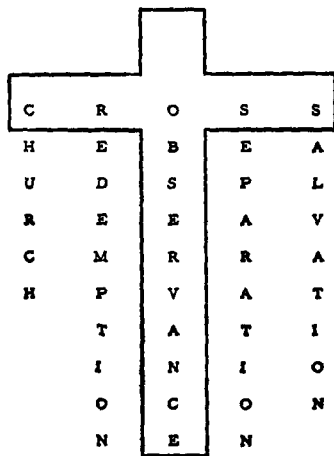

2. *The church centers around the cross.* (1) The blood shed on the cross purchased the church (Acts 20:28). Hence, if man can be saved out of the church, he can be saved without being blood-bought. (2) The head of the church is he who died on the cross (Eph. 1:22,23; 5:23). (3) That which is preached by the church is the gospel which grew out of the cross (I Cor. 1:18; I Tim. 3:15).

3. *Redemption centers around the cross.* (1) Eph. 1:7; 2:16; I Jno. 1:7. (2) How are we saved by the blood? Christ's blood was shed in his death. We are baptized into his death (Rom. 6:3,4). It is there that we reach the blood, sins are forgiven (Acts 22:16), and we become a part of the blood-bought church (Acts 2:41).

4. *Observance centers around the cross.* (1) Our observance of the Lord's supper shows the death of Him who died on the cross (I Cor. 11:26). (2) Jesus could have had us to erect a cross on every corner; but he did not; instead, he gave the Lord's supper as a memorial (I Cor. 11:24,25). (3) Each should examine self (I Cor. 11:28). (4) It should be taken in a worthy manner (I Cor. 11:29).

5. *Separation of God's covenant centers around the cross.* (1) The law of Moses died when Jesus died on the cross (Col. 2:14). It was intended to be only temporary (Gal. 3:19). (2) The New Testament dispensation could not go into effect until sometime after Jesus died (Heb. 9:16,17). It is a better covenant (Heb. 8:6-10). Today we must hear Jesus (Matt. 17:1-5; Heb. 1:1,2).

6. *Salvation centers around the cross.* (1) Jesus died for our sins (I Cor. 15:3). The Jews sacrificed literal lambs. Jesus was the lamb of God which took away sin (Jno. 1:29). (2) The preaching of the cross is God's power to save (I Cor. 1:18). Man becomes free from sin when he obeys the form of doctrine (Rom. 6:17,18). The doctrine itself is the death, burial, and resurrection of Christ (I Cor. 15:1-4). We obey its form. How? Die to sin; buried in baptism; raised to walk in newness of life (Rom. 6:3,4).

CAUSE AND EFFECT

Introduction. We recognize the law of cause and effect. Every effect has its cause. There are many unscriptural effects in the religious world and each has its unscriptural cause.

Cause	Effect
1. Misunderstanding. Matt. 16:-18; I Cor. 12:20; Eph. 4:4; 2:16.	1. Many churches.
2. Some are not walking with Christ. Two men cannot walk with the third one unless all walk together (Amos 3:3). I Cor. 1:10; 3:3; Jno. 17:20,21.	2. Religious division.
3. A desire to alter God's word. Deut. 4:2; Rev. 22:18,19; II Tim. 3:16,17.	3. Human creeds.
4. Following men instead of Christ. I Cor. 1:11-13; Acts 11:26; I Pet. 4:16.	4. Human names.
5. Pride. Matt. 23:5-12; Job 32:21,22.	5. Religious titles.
6. A desire to please self. Gal. 1:10; Matt. 6:10; 26:39. Should walk by faith (II Cor. 5:7).	6. Instrumental music in worship.
7. Belief in hereditary depravity. Ezek. 18:20.	7. Infant baptism.

NOTHING

1. *Introduction.* Brother J. T. Stricklin, an elderly preacher, arose at the conclusion of a service and said, "Brother Brownlow has preached something for these many years. Now I would like to hear him preach on nothing." I replied, "The Lord willing, I shall preach on 'Nothing' next Lord's Day." This is the sermon.

2. *Out of nothing God created the world* (Gen. 1:1).
 (1) This is the only way to account for creation. We have to begin with a self-existent Being who created some-

thing out of nothing. The evolutionist has to start with something. Ask him where that something came from. (2) Man can rearrange, re-design, but he cannot create.

3. *Man brought nothing into this world and will carry nothing out* (I Tim. 6:7). (1) Hence, "godliness with contentment is great gain" (I Tim. 6:6). (2) Since man can carry nothing out of this world, then the purpose of his stay here is not a quest for the material. The purpose of our stay is spiritual (Eccl. 12:13), a preparation for another life (Amos 4:12). (3) If you lose sight of this, you will come up with nothing when you die, because the material cannot be taken with you. Matt. 6:19,20.

4. *Jesus said, "For without me ye can do nothing"* (Jno. 15:5). (1) Morality minus Christ equals nothing (Jno. 15:4). $M - C = 0$. (2) Christ is Saviour (Matt. 1:21); he is the way (Jno. 14:6). (3) Christ's gospel is the power to save (Rom. 1:16). (4) Christ will save his church (Eph. 2:16; 5:23,27).

5. Belief plus baptism equals salvation (Mk. 16:16). Just like 1 plus 1 equals 2. But 1 minus 1 equals nothing. Therefore, *belief minus baptism equals nothing*.

$$\begin{aligned} B+B &= S \\ 1+1 &= 2 \\ 1-1 &= 0 \\ B-B &= 0 \end{aligned}$$

6. Repentance plus baptism equals remission of sins (Acts 2:38). Just like 1 plus 1 equals 2. But 1 minus 1 equals nothing. Therefore, *repentance minus baptism equals nothing*.

$$\begin{aligned} R+B &= R \text{ of } S \\ 1+1 &= 2 \\ 1-1 &= 0 \\ R-B &= 0 \end{aligned}$$

Paul had believed and repented, but it still equaled nothing (Acts 22:16).

7. *Religious acts minus love equals nothing* (I Cor. 13:1-3). (1) Faith minus love equals nothing (I Cor.

13:2). (2) Benevolence minus love equals nothing (I Cor. 13:3). (3) First and great commandment deals with love (Matt. 22:37,38). (4) Love would solve many problems in the church (Jno. 14:23).

8. *"If the salt have lost his savor . . . it is thenceforth good for nothing"* (Matt. 5:13). (1) Salt seasons, saves, and preserves. (2) If a child of God has lost the qualities which made him salt, he is good for nothing. So Christians may become good for nothing — good-for-nothing church members.

9. *"I will destroy the wisdom of the wise, and will bring to nothing the understanding of the prudent"* (I Cor. 1:9). (1) Man's wisdom minus God equals nothing. Learning must be mixed with God to be something (I Cor. 1:18). (2) I Cor. 1:25-27. (3) We need this lesson in the church today. We should not emphasize secular training to the neglect of spiritual training. A preacher can have two or three college degrees and not know enough about the Bible to defend it.

10. *"As having nothing and yet possessing all things"* (II Cor. 6:10). (1) "Having nothing." Destitute. No physical possessions. (2) "Having all things." Think! How much the Christian possesses!

11. *Conclusion.* If we lose our souls, we have gained nothing in this life (Mk. 8:36,37).

GOD IS GOOD

Lk. 18:19; Rom. 11:22

G — Generous. Phil.4:19; Jas.1:5,17; I Tim.6:17; Jno.3:16.

O — Omniscient. Psa. 139:1-6; Matt. 6:8.

D — Deathless. Psa. 90:2,4.

I — Impartial. Acts 10:34,35; I Pet. 1:17.

S — Sincere. Heb. 6:18; II Pet. 3:9.

G — Gracious. Tit. 2:11; Eph. 2:8.

O — Omnipotent. Gen. 1; Jer. 32:17.

- O — Omnipresent. Psa. 139:7-10; Psa. 23; Acts 17:27.
 D — Decisive. Gen. 18:25.
-

“HE WENT AWAY SORROWFUL”

Matt. 19:16-22

Introduction. Sorrowful — this describes the young man who went away from Jesus. Coming to Jesus brings joy (Acts 8:35-39; 16:31-34). Going away from Him brings sorrow. In going away sorrowful he also went away in other states, as we shall see.

S — *Sinful.* (1) He had an idol in his heart (Col. 3:5). (2) Ex. 20:3. (3) What is sin? Transgression of law (I Jno. 3:4), or omission of duty (Jas. 4:17).

O — *Opinionated.* (1) Had his own opinion which was different from the Lord's command. True of many. (2) The Christian life is one of faith (II Cor. 5:7; Gal. 2:20). Faith is based on God's word (Rom. 10:17).

R — *Rash.* (1) If he had weighed the matter, he would not have been so reckless and hasty. He showed a disregard for the consequences. (2) A man's soul is too precious for him to be so rash (Mk. 8:36,37). (3) In going away from Jesus one departs: A. From Saviour (Matt. 1:21). B. From Him who gives life (Jno. 5:40). C. From light and walks in darkness (Jno. 8:12). D. From Him whose word will judge us (Jno. 8:12). (4) The rich young man should have taken the attitude of the man seeking goodly pearls (Matt. 13:45).

R — *Rebellious.* (1) Rebellion in the life of Saul (I Sam. 15:23). (2) The rebellious spirit that prompts a man to reject the authority in one command is equivalent to rejecting the Lord's

authority in all commands. (3) Jer. 10:23; Matt. 6:10; Heb. 5:8,9.

O — *Opulent*. This means having a large estate, wealthy. (1) Happiness comes from within, not from wealth (Lk. 12:15). (2) Wealth is only a means to an end, and should be a servant rather than a master. Joseph of Arimathea used it in such a way (Matt. 27:57-60). (3) I Tim. 6:7.

W — *Willing*. He turned away of his own accord. Man is a creature of volition and choice (Josh. 24:15; Matt. 11:28-30; Matt. 23:37; Acts 13:46).

F — *Frustrated*. (1) He was caught between two decisions and was not happy with either. (2) Wholeheartedness is an antidote for frustration, because man cannot serve two masters (Matt. 23:37; 6:24; 6:33).

U — *Unrepentant*. (1) He brought forth no fruits of repentance (Matt. 3:8). (2) Lk. 13:3; Acts 17:30.

L — *Lost*. (1) He rejected the only way of life (Jno. 14:6). (2) Salvation brings joy; the lost state brings sorrow. The lost person has no God, no Christ, no Saviour, no hope, no heaven.

CHRISTIAN

A Christian is:

C — Charitable. Acts 2:45; Matt. 22:39; Gal. 6:10.

H — Humble. Matt. 18:4; I Pet. 5:4; Phil. 2:8,9.

R — Repentant. Acts 17:30; Lk. 15:18,19.

I — Instructive. Mk. 16:15,16; Acts 8:4; Heb. 5:12.

S — Sanctified. I Cor. 1:2; Rom. 13:2; Jas. 4:4; Heb. 11:24-27.

T — Tireless. Gal. 6:9; I Cor. 15:58; Rev. 22:10.

I — Illuminant. Matt. 5:14-16; Phil. 2:15.

A — Affable. I Tim. 3:3; Phil. 2:3; I Pet. 3:8.

N — Narrow. Matt. 7:13,14; Rom. 12:2.

GCSPSEL

- G** — *God-given.* (1) God spoke through the Son (Heb. 1:1,2; 2:3,4). (2) Holy Spirit guided apostles (Jno. 14:26; 15:26; 16:13). (3) "The gospel which was preached of me is not after man" (Gal. 1:11,12). (4) "Now the Spirit speaketh" (I Tim. 4:1). (5) Man did not give the gospel, but he can pervert it (Gal. 1:7-9; Matt. 15:9).
- O** — *Ordinance-containing.* It is decreed that man: (1) Believe (I Jno. 3:23; Jno. 8:24). (2) Repent (Acts 17:30; Lk. 13:3). (3) Be baptized (Acts 2:38; 10:48). (4) Add to the faith (II Pet. 1:5-10).
- S** — *Soul-saving.* (1) Rom. 1:16; I Pet. 4:17, 18; II Thess. 1:8,9; Acts 2:47. (2) In their eagerness to help society, many have forgotten that the gospel was designed first of all to save the soul (Matt. 1:21; Lk. 19:10; Jas. 1:21).
- P** — *Promissory.* Through the gospel the Lord promises us: (1) Remission of sins (Acts 2:38). (2) Eternal life (I Jno. 2:25). (3) To be with us (Matt. 28:20). (4) Necessities of life (Matt. 6:33). (5) That all things work together for our good (Rom. 8:28).
- E** — *Effective.* (1) It was elevating and reformatory in the lives of Paul (I Tim. 1:13), Onesimus (Philemon 10,11), Thessalonians (I Thess. 1:9), and the people on Pentecost (Acts 2:36-47). (2) It was so powerful that those who preached it had the reputation of turning the world upside down (Acts 17:6).
- L** — *Lasting.* (1) It endureth forever (I Pet. 1:25; Matt. 24:35). (2) It will be there to face us at the judgment (Jno. 12:48; Rev. 20:12).
-

A GOOD MAN'S FALL AND RETURN

Introduction. That man was Simon Peter. Let us note the downward steps in his fall and the upward steps

in his return. Here is a practical lesson for every Christian:

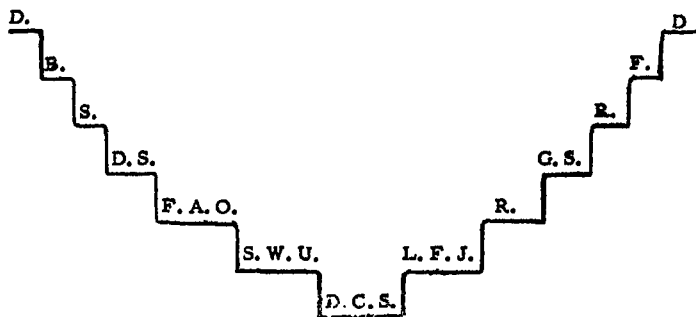

His fall.

1. *He doubted* (Matt. 14:22-31). As he walked on the sea, his faith weakened; he doubted; he began to sink. It is necessary that our faith remain strong (Heb. 3:12). Faith supports us (Psa. 27:13).

2. *He boasted* (Mk. 14:27-31). Peter said, "I will not deny thee." He boasted of his loyalty. We may say that we will not do a certain thing, but "Wherefore let him that thinketh he standeth take heed lest he fall" (I Cor. 10:12).

3. *He slept* (Mk. 14:32-42). This was physical sleep; it occurred in Gethsemane. Today many are spiritually asleep and God calls on them to awake (Eph. 5:14; I Thess. 5:16). The sleeper is helpless. There is no need to call on him to pray, to read, to preach, or to lend a helping hand, for he is asleep.

4. *He drew his sword* (Mk. 14:43-47). Facing the mob in Gethsemane, he did this in the defense of Christ.

It was a rash act. Christ cannot be defended with any sword other than the sword of the Spirit, the word of God (Heb. 4:12).

5. *He followed afar off* (Lk. 22:54). This took place after Jesus was arrested. No man can follow Christ afar off for long without finally losing sight of him. We should follow as close to Jesus as possible (Matt. 16:24; I Cor. 11:1; 14:12).

6. *He sat with unbelievers* (Lk. 22:55). Evil influences overcame him. Evil associations corrupt good morals (I Cor. 15:33). If he had been in the presence of others, it might have been different.

7. He then *denied, cursed, and swore* (Matt. 26:69-74). He had fallen. He had reached the state which the Lord has warned us against (Matt. 26:41; II Pet. 1:10).

His return.

1. *A look from Jesus penetrated him* (Lk. 22:61). The thought that Jesus is watching us should have a sobering effect upon us (Heb. 4:13; Prov. 15:3).

2. *He remembered* the words of Jesus (Matt. 26:75). A remembrance of Christ's words will lift us up; forgetfulness of them will pull us down. Jesus said to the lukewarm church at Laodicea, "Remember therefore from whence thou art fallen, and repent" (Rev. 2:5). Every fallen person needs to remember — remember how he once lived a better life and remember the words of Jesus.

3. He became possessed with *godly sorrow* (Lk. 22:62). He wept bitterly. This was not worldly sorrow, for the things of the world did not produce it. It came because he realized what he had done to Jesus.

4. *He repented*. We know that he did, for godly sorrow works it (II Cor. 7:10). His life indicated it. He brought forth fruits meet for repentance (Matt. 3:8).

5. *He was faithful*. He was not sinless, for Paul later rebuked him "because he was to be blamed" (Gal. 2:11). But he continued in the Christian race and was faithful unto death. This is essential (Rev. 2:10).

6. *He died for Christ*. Jesus prophesied that Peter

would die a martyr's death (Jno. 21:18,19). According to secular history it came to pass that way. He was no longer afraid. He fearlessly and heroically preached Christ. He died for his faith.

WHAT IS DEATH?

1. *Death is not:* (1) The means of converting a wicked person into a Christian (Lk. 16:19-31). As one dies so is he. (2) The extinction of man (Lk. 16:19-31). Both the good and the bad continued to live after death.

2. *Death is an appointment* God has made for us (Heb. 9:27). (1) We are pilgrims on earth (Heb. 11:13). (2) Nothing permanent here. Through the centuries the strictest Jews have left unfinished various parts of their homes, usually the cornice or some other conspicuous spot. The purpose of this is to remind them that nothing here is finished, that like Abraham of old they are pilgrims and strangers on earth.

3. *Death is both certain and uncertain.* It is certain to come (Gen. 3:3), but the time is uncertain (Jas. 4:14).

4. *It is the end of labors* that will be rewarded. Eccl. 9:5,10; Jno. 9:4. The rich man waited too late (Lk. 16:26).

5. *It is a state over which the Lord has power.* The Lord will raise the dead (I Cor. 15:51-55; Jno. 5:28,29; I Thess. 4:16).

6. *Death is the last enemy* of man to be conquered by the Lord (I Cor. 15:25,26).

7. *Death is a departure.* (1) From the world (Eccl. 12:5). (2) From the body (Eccl. 12:7; Jas. 2:26). (3) The silver cord will be loosed (Eccl. 12:6). Song: "Some Day the Silver Cord Will Break." (4) A sign in front of a house read: "This house for rent. Is the former tenant dead? No, he has moved to a larger house in a better situation."

8. *Death was designed to be gain* (Phil. 1:21).

9. *Death is an emancipation* for the righteous. (1)

Rest from labors (Rev. 14:13). (2) No pain, sorrow, death, tears — those former things are passed away (Rev. 21).

10. *Death serves as transportation*, an exit from this world and an entrance into another world (Gen. 35:18). It is necessary that we put off this physical body of flesh and blood (I Cor. 15:50).

11. *Death is not the end of man's influence* (Rev. 14:13). This is another argument for the immortality of man. If man's influence does not die, it stands to reason that man does not die either.

“I WILL . . . BEFORE I DIE”

Gen. 45: 28.

1. *Introduction*. These words came from the mouth of Jacob. Give the context.

2. *Death is sure*. Psa. 90:10; Job. 14:1,2; Jas. 4:14; Heb. 9:27.

3. *Death is in the good interest of man*. (1) It was not good for man to live forever in a state of sin and rebellion. This is why man was driven from the garden (Gen. 3:22-24). (2) The earth is not man's eternal home (Eccl. 12:7; II Cor. 5:1).

Why should you be forlorn?

Death only husks the corn.

Why should you fear to meet
the thresher of the wheat?

(3) These bodies are not adapted to heaven. Flesh and blood cannot inherit the kingdom of God (I Cor. 15:50). He will give us a new body like his own (Phil. 3:21). (4) Phil. 1:21; Psa. 116:15. (5) There is a fable which states that the people of earth met and asked death to cease her labors on earth. The request was granted. The young became old. The aged became older. The sick became sicker. Those who writhed in pain had no escape from their misery. Man's burdens became heavier. The earth became crowded. People were born, but no one died.

Life became unbearable. So the people convened and asked death to take her toll again. In this world we must have death to have life.

4. *Whatever we intend to do must be done before we die.* (1) Psa. 6:5. (2) Eccl. 9:10. Three questions are answered in the verse. A. What? "Whatsoever thy hand findeth to do" — what is necessary to be done in this life. B. How? "With thy might." Act with all your strength and all your heart. C. Why? "For there is no work, nor knowledge, nor wisdom, in the grave, whither thou goest." The state of probation now enjoyed will be forever ended. No work, device, knowledge, or wisdom will restore the dead sinner to the favor of God.

5. *Story of the rich man and Lazarus* (Lk. 16:19-31). (1) Neither the saved nor the lost went to purgatory. There is no purgatory. (2) Rich man wanted to go to heaven, but waited too late to make the preparation. Amos 4:12. (3) Rich man wanted to become a soul winner, but waited too late. (4) He waited too late to hear God's word.

6. "*Now*" and "*today*" are great words in the Bible (II Cor. 6:2; Heb. 4:7).

7. We should make peace in this life with man and God. (1) Relative to man, we are taught to love neighbor (Matt. 22:39) and to make amends if there is aught against us (Matt. 5:23,24). (2) Relative to God, remember Isa. 59:2 and Rom. 6:17,18.

8. *Let us perform our duties now* lest time run out on us. A man on a train said, "I am hurrying to the beside of my aged father. I want to take his old hand in mine and caress it, look into his dim eyes again, and thank him for every licking he ever gave me. I just hope I am not too late."

MAN MAY DO SEVERAL THINGS AND STILL BE LOST

1. *May hear and be lost.* (1) True of the people in Antioch (Acts 13:44-46) and of Felix (Acts 24:24,25).

(2) Hearing and not doing is self-deception (Jas. 1:22-25).

2. *May believe and be lost.* True of the rulers (Jno. 12:42,43; Matt. 10:33).

3. *King Agrippa* was almost persuaded to be a Christian, but was still lost (Acts 26:28).

4. *Simon who had been a sorcerer* was baptized and later became lost (Acts 8:13,21,22).

5. *May be a disciple and be lost.* (1) True of some because they turned back (Jno. 6:66). (2) The one who turns back is not fit for the kingdom of God (Lk. 9:62).

6. *Judas* was unusually close to the Lord for awhile, but was lost (Lk. 22:3; Acts 1:25). Must endure unto the end (Matt. 10:22; Rev. 2:10).

7. *The Pharisees* were religious, but were condemned (Matt. 23).

8. Jesus stated that *many who had done wonderful works* would be condemned (Matt. 7:21-23). (1) This will occur because they did not the Father's will (Matt. 7:21). (2) Obedience is essential (Heb. 5:8,9; Rev. 22:14).

9. *Many who have zeal* will be condemned because they had not knowledge (Rom. 10:2). Knowledge precedes conversion (Matt. 13:15; Jno. 8:32).

10. *Foolish virgins* made some preparation to meet the bridegroom, but were not permitted to enter (Matt. 25:1-13). They were not ready (Matt. 25:10).

PREACHING ON THE ROSTRUM

1. *Introduction.* Several have asked through the years, "What are you preaching on? the rostrum?" Well, I have decided I would.

2. *This is a scriptural topic.* (1) Jesus used a ship for a rostrum (Lk. 5:1-3). (2) Paul used Areopagus for a rostrum (Acts 17:19).

3. *A rostrum is only a means to an end* — not an end within itself. (1) Can remember when churches had rost-

rum that were seldom ever used. (2) A church building is also a means to an end. (3) Great Commission is a means to an end. Going and preaching is the means, while the end is salvation (Mk. 16:15,16). (4) Assembling on the Lord's day (Heb. 10:25) is a means to an end which is worship (Jno. 4:23,24).

4. *The fact that denominationalists use a rostrum does not make one wrong.* (1) They also believe in God and in Christ (Heb. 11:6; Jno. 8:24), believe in repentance (Lk. 13:3), attend worship (Heb. 10:25), and read the Bible (I Tim. 4:13). (2) Neither does the fact that the majority use one make it right (Matt. 7:13,14). (3) Both a doctrine and a practice must be judged by its own merit and not by its adherents.

5. *The fact that a rostrum can be misused — used to teach error — does not necessitate that it be discarded.* Every good thing can be perverted; for instance: (1) Women teachers (Tit. 2:3-5; I Tim. 2:12; I Cor. 14:34,35). (2) Confession (Matt. 10:32; Rom. 10:10). But some confess wrong thing — even allegiance to a human creed. (3) Baptism (Acts 2:38; Rom. 6:3,4). But many are baptized wrong way for wrong purpose.

6. *As the rostrum or pulpit goes, so goes the church.* (1) The soundness of a church does not depend upon its size, but upon its teaching and preaching. (2) We must obey I Tim. 4:16 and II Tim. 2:2.

7. *It is essential that we have the combination of the rostrum and the pew.* (1) Must have hearers or there would be no need to have preachers. (2) We need good preachers, but we also need good hearers (Jas. 1:22-25; Matt. 13:15; Acts 7:57; Lk. 8:18).

8. *Some regard the rostrum as only a target.* They come, sit, and criticize the preacher, song director, announcer, and the one who leads prayer. (1) Should obey Matt. 7:3-5 instead. (2) The Lord expects no more of us than our ability permits (Matt. 25:14-30). (3) It is bet-

ter to be criticized for well doing than for evil doing (I Pet. 3:17).

9. *The work of the rostrum can never take the place of individual work.* (1) Even Jesus, who occupied the rostrum, went out and taught personally (Jno. 3 and 4). (2) The Great Commission binds personal evangelism upon every disciple (Matt. 28:19,20). The rostrum cannot do the individual disciple's work for him.

BACKSLIDING

1. *Introduction.* (1) Backsliding is a Biblical expression. It is used about fifteen times in the Bible — twelve times by Jeremiah to describe the condition of Israel. (2) Definition: "To slide back; to lapse morally."

2. *We are warned against backsliding.* Matt. 26:41; Heb. 3:12; I Cor. 10:12; II Pet. 1:10.

3. *Examples of backsliding.* (1) Galatians (Gal. 5:4). (2) Simon the sorcerer (Acts 8:18-22). (3) Demas (II Tim. 4:10). (4) Ephesians (Rev. 2:4,5).

4. *Results of backsliding.* (1) Makes one fit only to be trodden under the feet of men (Matt. 5:13). (2) Renders one unfit for the kingdom (Lk. 9:62). (3) This state is worse than the first (II Pet. 2:20-22). (4) Everybody loses. A. Local church loses a member. B. God loses a worker (II Cor. 6:1). C. The brethren lose a brother or sister (II Tim. 4:10). D. The community loses a Christian's influence (Matt. 13:33). (5) The backslider loses his soul (Jno. 15:1-6).

5. *Our attitude toward the backslider.* (1) Restore him in the spirit of meekness considering self (Gal. 6:1). (2) Convert him (Jas. 5:19,20).

6. *Backsliding preventives.* (1) Add the Christian graces (II Pet. 1:5-10). (2) Meet the requirements for growth (I Pet. 2:2). (3) Watch and pray (Matt. 26:41). (4) Take heed (I Cor. 10:12; Heb. 3:12).

WORDS AGAINST THE LORD

Mal. 3:13,14

1. *Introduction.* (1) We learn from the text that there were some who openly spoke against the Lord in Malachi's day. They asserted that divine worship, obedience to God, and repentance were useless; that if they did those things they were no better off; and if they refused, they were none the worse off. (2) There are many today who speak against the Lord in every conceivable way.

2. *Some speak words against God's existence.* (1) They say the idea of God is only a fable. When Mr. Ingersoll was asked if he believed in God, he replied, "Well, I have never seen one." Neither had he seen electricity, pain, nor sorrow; but thy exist. (2) Such people are called fools (Psa. 14:1). (3) Even the heavens declare the glory of God (Psa. 19:1). (4) Why should the idea of God be thought incredible when humanity everywhere testifies to the need of God? Man's need of God is so great that those who know not the true God create a god for themselves.

3. *Some speak against God's creative power.* (1) They try to explain the world in terms of evolution. But the evolutionist has to have something with which to start, and he does not know how to get that something. (2) The only explanation of creation is found in Gen. 1:1 which begins with an all-powerful, self-existent Being.

4. *Some speak against God's word.* (1) They deny that the Bible is God's inspired message. But if there is a God — and there is — it is reasonable to assume that he would communicate with man in a definite and concrete manner; so the Bible is a reasonable thing. (2) The Bible is inspired (II Tim. 3:16,17; II Pet. 1:21). (3) It is easy to prove the Bible is true.

5. *The words of some are stout against God's Son.* (1) They say Christ was a good man but was not the Son of God. But if he was a good man — and he was — then he was the Son of God; because he claimed to be the Son

of God (Jno. 5:17-23) and good men do not lie. (2) He was the only begotten Son of God (Jno. 1:14), begotten by the Spirit, and born of a virgin (Matt. 1:18-23). (3) The dual nature of Jesus — Son of man and Son of God — qualified him as the one mediator between God and man (I Tim. 2:5); because a mediator should be equi-distant between both parties.

6. *Some utter words against God's ability.* (1) They accuse God of writing a book that man is unable to understand. This reflects upon God's ability. (2) Christianity is a religion to be taught and can be understood. Matt. 28:19,20; Isa. 35:8; Matt. 13:15; Jno. 8:32; II Tim. 2:15. (3) It is evident that if we understand it at all, we understand it alike.

7. *Some speak against God's impartiality.* (1) They accuse God of electing some people to salvation and predestinating others to condemnation, without the choice of either — Calvinism. (2) But God loved the whole world (Jno. 3:16) and would that all be saved (I Tim. 2:3,4). Jesus died for all (Heb. 2:9) and invites all (Matt. 11:28-30). (3) Man makes his own election sure (II Pet. 1:5-10). (4) God is no respecter of persons (Acts 10:34,35).

8. *Some speak against God's fairness.* (1) They accuse the Lord of holding an infant responsible for the sin of Adam and Eve — hereditary depravity. (2) But sin is an individual thing (Ezek. 18:20). (3) The infant is born guiltless (Matt. 18:3) and becomes guilty of sin in youth, not in infancy (Gen. 8:21).

9. *Some speak against God's sincerity.* (1) They accuse the Father of hypocrisy. They say that God is behind all the religious faiths, doctrines, and bodies in the world. They say that God has called one man to deny what he has called another to affirm. If one man were to preach one doctrine one night and preach the very opposite the next night, you would say that he is a hypocrite. Well, what does it make of God, if he does it? (2) God is not responsible for the divided state of Christendom. Matt. 16:18; Eph. 4:4-6; Phil 3:16; I Cor. 1:10-13; Jno. 17:20,21.

10. *Some speak against God by taking his name in vain.* Ex. 20:7; Jas. 3:9-12.

MIND YOUR OWN BUSINESS

1. *It was God's business to send the Son* (Gen. 3:15; Isa. 53; Jno. 3:16,17; Rom. 5:8). It is man's business to believe in the Son and accept him (Jno. 8:24; Jno. 12:48; Jno. 6:66-68).

2. *It was the Holy Spirit's business to give us the Bible* (II Pet. 1:21; Jno. 14:26; 15:26; 16:13). It is man's business to accept the Bible and follow it — not change it (Deut. 4:2; Rev. 22:18,19; Gal. 1:7-9).

3. *It was the Holy Spirit's business to give us the plan of salvation: hear* (Rom. 10:13,14); believe (Heb. 11:6); repent (Lk. 13:3); confess (Matt. 10:32); be baptized (Acts 2:38). It is man's business to obey the plan (Heb. 2:3; I Pet. 4:17; II Thess. 1:8,9; Acts 2:40).

4. *It is God's business to forgive man of sin* (Matt. 6:12; Acts 8:22). God has not given any man the business of remitting sins. What about Jno. 20:23? This is a promise that the Holy Spirit would come to the apostles authorizing them to lay down the conditions on which men could be forgiven, the conditions on which sins could be remitted and which they could not be remitted. Neither is it man's business to forgive himself. Some think it is; say that they are forgiven because they have forgiven themselves. Forgiveness take place in the mind of God — not in the mind of man.

5. *It was Christ's business to found the church* (Matt. 16:18; Acts 20:28). It is man's business to comply with the terms of admission that he may be added to it (Acts 2:40-42,47) — not found a church of his own (Matt. 15:13,14).

6. *It is the Lord's business to add to the church* (Acts 2:47). It is not man's business to open and close the door of the church. The keys to the church were given to the apostles (Matt. 16:19; 18:18) and they opened the door of

the church on Pentecost (Acts 2) and it has been open ever since. It is rather man's business to preach and baptize (Mk. 16:15,16; Matt. 28:19,20).

7. *It is the Lord's business to judge* (Jno. 5:30; Matt. 25:31-46). It is man's business to preach the gospel as God gave it (Mk. 16:15,16; Gal. 1:8,9). To do so is not judging; it is obeying God.

8. *Conclusion.* The troubles in the religious world are the result of man's getting away from his own business and trying to mind the business of God.

GREAT DECISIONS OF THE BIBLE

1. *Introduction.* Life is filled with decisions every day. A study of great decisions men made centuries ago should help us in making ours.

2. *Adam and Eve decided to disobey* God and follow the serpent instead (Gen. 3). (1) Here we see that life for man began with decisions. He has had to make them ever since. (2) Their wrong decision was influenced by human appetite and a desire to be wise (Gen. 3:6). (3) The consequences of their decision are still with us (I Cor. 15:22). Our decisions may affect many generations yet to be born.

3. *Abraham unhesitatingly decided to offer Isaac* (Gen. 22:1-13). (1) A tremendous decision, a violent step, contrary to human judgment. (2) It was faith that influenced him to make the right decision (Heb. 11:17-19).

4. *Lot chose the well-watered plain of Jordan* (Gen. 13:1-13). (1) It looked like a smart decision, but it wasn't. It led to the loss of his family (Gen. 19:1-26). (2) He let material things influence him too much in the decision. Choosing a place to rear a family should never be determined solely by the material.

5. *Moses chose "rather to suffer affliction with the people of God, than to enjoy the pleasures of sin for a season"* (Heb. 11:24). He had much to give up. Why did he do it? (1) Because of faith (Heb. 11:24) — the

decision came from within and not from without. (2) Because "he had respect unto the recompense of the reward" (Heb. 11:26) — the sufferings were nothing in comparison with the reward. (3) Because he saw "him who is invisible" (Heb. 11:27) — a glimpse of the unseen settled it.

6. *King Saul unwisely decided to spare the best of the Amalekites* (I Sam. 15). (1) Fear of the people prompted the wrong decision (I Sam. 15:24). (2) Eccl. 12:13; Matt. 10:28.

7. *Naaman* (II Kings 5). (1) His first decision was prompted by the following: First, a wounded pride. Elisha, instead of going to see him, sent a servant (II Kings 5:10). Second, a preconceived idea. He thought the means of his cure would be different from that ordered (II Kings 5:11). Third, prejudice. He thought Abana and Pharpar were better than all the waters of Israel (II Kings 5:12). (2) He later overcame the obstacles and made the right decision (II Kings 5:13,14). His future depended upon it. Our future is also determined by our decisions.

8. *Joshua's decision*. He said, "Choose you this day whom ye will serve . . . but as for me and my house, we will serve the Lord" (Josh. 24:15). (1) His decision was based on the fact that the Lord was the true God and that he had done much for them. (2) The same fact should influence us to make the right decision. If God is God, then that settles the matter. We should be either infidels or devoted followers of God. The very nature of the issue leaves no place for a middle position, and there is none (Matt. 12:30).

9. *Christ's decisions*. (1) Satan presented three propositions to Christ that required decisions (Matt. 4:1-11). (2) Jesus made the right decisions because he had the Scriptures upon his heart and lips. He could say, "It is written . . ."

10. *Pilate had to decide an answer to his own question*: "What shall I do then with Jesus which is called Christ?" (Matt. 27:22). (1) He did not want to make

the decision. This is true of many, but there is no escape. (2) Pilate was influenced by the people. Ex. 23:2; Matt. 7:13,14.

11. *Jesus invites us* (Matt. 11:28-30; Rev. 3:20).

- (1) This necessitates a decision; there is no alternative.
 (2) Excuses are useless (Lk. 14:16-24).

PRICES WE PAY

1. *Introduction.* There is a price behind everything that is worthwhile. The things that are good do not come free. We should not expect something for nothing.

2. *The price for pardon.* (1) Do God's will instead of ours (Matt. 6:10; Jas. 5:30). (2) God's will is: A. Believe (Jno. 8:24). Give yourself an opportunity to believe (Rom. 10:17). B. Repent (Lk. 13:3). C. Confess Christ (Matt. 10:32,33). A secret confession will not suffice. D. Be baptized (I Pet. 3:20,21; Rom. 6:3,4).

3. *The price for greatness.* (1) Service (Matt. 20:27). Greatness is not derived from office, position, or uniform, but from service. (2) Humility (Matt. 18:4; Prov. 16:18).

4. *The price for friends.* (1) Be friendly; be a friend (Prov. 18:24). (2) Be unselfish (Phil. 2:4). (3) Treat others as you wish to be treated (Matt. 7:12).

5. *The price for financial security.* (1) Work to have (Eph. 4:28). Prov. 6:6-11; 30:25. (2) Be thrifty. Prodigal wasted (Lk. 15:13). Prov. 18:9.

6. *The price for knowledge.* (1) It is not like it was when people spoke by inspiration (Jno. 14:26). (2) Must study (II Pet. 1:5; II Tim. 2:15; Psa. 1).

7. *The price for spiritual strength.* The requirements are similar to those for physical strength: food (I Pet. 2:2), freedom from spiritual disease or sin (Jno. 8:21), exercise (I Tim. 4:7), and time (Heb. 5:12).

8. *The price for heaven:* (1) Live Christ (Phil. 1:21). (2) Abide in Christ (Jno. 15:6). (3) Die in Christ (Rev.

14:13). (4) A person cannot have everything. He can have heaven, but at the expense of giving up the world. Or he can have the world, but at the price of giving up heaven.

YOU AND YOUR BROTHER

1. *It is difficult to win an offended brother* — “A brother offended is harder to be won than a strong city” (Prov. 18:19). (1) If each had the spirit of a child, it would not be difficult (Matt. 18:3). (2) If each had the spirit of forgiveness, the difficulty would vanish (Col. 3:13). (3) If you have offended a brother, you should try to be reconciled to him (Matt. 5:23,24). This has reference to an actual offense.

2. *You should not imagine evil against your brother* — “And let none of you imagine evil against his brother in your heart” (Zech. 7:10). (1) Too many people let their imaginations and suspicions run wild. They judge without the facts (Matt. 7:1-5). (2) “For every tree is known by his own fruit” — not by the way the leaves are blowing (Lk. 6:44).

3. *You should have right attitude toward your brother* — “But I say unto you, That whosoever is angry with his brother without a cause shall be in danger of the judgment: and whosoever shall say to his brother, Raca, shall be in danger of the council: but whosoever shall say, Thou fool, shall be in danger of hell fire” (Matt. 5:22). (1) “In danger of the judgment.” This was the tribunal established by the law of Moses in each city for the trial of criminals (Deut. 16:18). (2) “In danger of the council.” This was the supreme court provided for by the Mosaic law (Deut. 17:8-13). (3) “In danger of hell fire.” This is the final punishment of the wicked. Here we see the climax of sin and the climax of punishment.

4. *You should forgive your brother* — “So likewise shall my heavenly father do also unto you, if ye from your

hearts forgive not every one his brother their trespasses" (Matt. 18:35). (1) And we are to keep on forgiving (Matt. 18:21,22). (2) We must forgive to be like Christ (Lk. 23:34). (3) We must forgive to get forgiveness (Matt. 6:14,15).

5. *You should not put a stumblingblock in your brother's way* — "That no man put a stumblingblock or an occasion to fall in his brother's way" (Rom. 14:13). (1) "But when ye sin so against the brethren, and wound their weak conscience, ye sin against Christ. Wherefore, if meat make my brother to offend, I will eat no flesh while the world standeth, lest I make my brother to offend" (I Cor. 8:12,13). (2) We should always strive to save a brother — never destroy him (Gal. 6:1).

6. *Your relationship with your brother should not be offensive to unbelievers* — "But brother goeth to law with brother, and that before unbelievers. Now therefore there is utterly a fault among you" (I Cor. 6:6,7). (1) We should not want to defraud (ver. 8). (2) We should be mindful of the unbelievers — "Walk in wisdom toward them that are without" (Col. 4:5).

7. *You should restore your fallen brother* — "Brethren, if a man be overtaken in a fault, ye which are spiritual, restore such a one" (Gal. 6:1). God has a law of pardon to an erring Christian (Jas. 5:16; Acts 8:22).

8. *You should withdraw from your disorderly brother* — "Now we command you, brethren, in the name of our Lord Jesus Christ, that ye withdraw yourselves from every brother that walketh disorderly" (II Thess. 3:6). (1) "That he may be ashamed" (II Thess. 3:14,15). (2) This should be done to save both him and the church (I Cor. 5:5,6).

9. *You should love your brother* — "Love the brotherhood" (I Pet. 2:17). (1) "Ye yourselves are taught of God to love one another" (I Thess. 4:9). (2) "Whosoever hateth his brother is a murderer" (I Jno. 3:15). I Jno. 2:9-11. (3) I Cor. 13.

"KEEP THYSELF"

I Tim. 5:22

1. *Introduction.* (1) It is a big job to keep self; and we are commanded to do it (I Tim. 4:16). (2) Each should think of self and ask, "Is it I?" (Matt. 26:22). (3) There are many things to do in keeping self.

2. *Keep yourself out of the business of others.* (1) Keep yourself out of "other men's matters" (I Pet. 4:15). We have all we can do to run our own business (I Thess. 4:11). (2) Keep yourself out of God's business. It was God's business to give the statutes and Scriptures (II Tim. 3:16,17). It is man's business to keep them (Psa. 119:145).

3. *"Keep thy heart with all diligence"* (Prov. 4:23). (1) The heart mentioned is the heart of the spiritual man; it is the heart with which we think, trust, believe, love, and obey. It is the source of conduct (Prov. 4:23). Every deed is first committed in the heart (Matt. 15:19). (2) Keeping the heart will keep one from adultery (Matt. 5:28), murder (I Jno. 3:15), and all other sins, including the sins of disposition which are the more common: hyper-criticism (Matt. 7:3-5), big-headedness (Phil. 2:3), selfishness (Phil. 2:4), envy (Prov. 14:30), and unforgiveness (Col. 3:13).

4. *"I will keep my mouth with a bridle"* (Psa. 39:1). (1) We must take heed lest we enter into gossip (Lev. 19:16), cursing (Ex. 20:7), filthy communication (Col. 3:8), and hasty speaking (Jas. 1:19). (2) "For he that will love life, and see good days, let him refrain his tongue from evil, and his lips that they speak no guile" (I Pet. 3:10).

5. *"I keep under my body and bring it into subjection"* (I Cor. 9:27). (1) "Abstain from fleshly lusts, which war against the soul" (I Pet. 2:11). The works of the flesh (Gal. 5:19-21). (2) The Christian must do this lest he be lost (I Cor. 9:27).

6. *"Little children, keep yourselves from idols"* (I Jno. 5:21). (1) God has always legislated against idola-

try (Ex. 20:3). (2) Excessive love or veneration for anything is idolatry. There are many forms of idolatry; for instance: image worship (Ex. 20:4), hero worship (Acts 14:8-18; 10:26), pleasure worship (I Cor. 10:7; II Tim. 3:4), covetousness or mammon worship (Col. 3:5), and self worship (Phil 3:19).

7. "*Keep himself unspotted from the world*" (Jas. 1:27). (1) This is pure and unspotted religion. (2) This keeps one from becoming a stumblingblock (Rom. 14:13). (3) A spotted soul is an occasion for the enemies of the Lord to blaspheme (II Sam. 12:14).

8. *Keep self sound in the faith* (I Tim. 6:20). (1) It has ever been a problem to keep the church sound in the faith (Gal. 1:6,7). Apostasy is a gradual thing, so gradual that many fail to detect it (II Tim. 4:3,4). (2) Each should have his senses exercised to discern good and evil (Heb. 5:14).

9. *Keep yourself in the unity and fellowship of other Christians* (Eph. 4:3). (1) It is a pleasant thing (Psa. 133:1). (2) It is something for which Christ prayed (Jno. 17:20,21). (3) God hates the sowing of discord among brethren (Prov. 6:16-19).

10. "*Keep yourselves in the love of God*" (Jude 21). He loved us while we were yet sinners (Rom. 5:8). God's love provided the sphere of salvation — the divine part. Man should live in that sphere — the human part. Hence, man keeps himself in the love of God by keeping himself in the plan God's love provided.

"WHEN THE ROLL IS CALLED UP YONDER"

1. *Introduction.* Comment on the song.

2. *No one knows when that time is coming.* (1) Matt. 24:36,37; Matt. 25:13; II Pet. 3:10. (2) Some prophecies have been fulfilled (II Thess. 2:3,4; I Tim. 4:1-3).

3. *When the time comes.* (1) The Lord will come (I Thess. 4:16-18; Acts 1:11). (2) Dead will rise (Jno. 5:28,29). (3) Living will be transformed (I Thess. 4:17).

(4) Time shall be no more. We are now living in the last days (Acts 2:17). (5) Work on earth will be over. Then we may rest from labors (Rev. 14:13). (6) Earth will melt (II Pet. 3:7-10).

4. *There is a book of life.* Phil 4:3. It will be opened at the judgment (Rev. 20:12).

5. *The Lord's roll may be quite different from church roll.* (1) It is man's business to baptize (Matt. 28:19), and God's business to add to church (Acts 2:47). (2) It is good for a church to keep a list of its members; but it may not be identical with the Lord's roll.

6. *Your name will not be there:* (1) Unless you meet the requirements for enrollment. The names of Paul's fellow-laborers were there (Phil. 4:3). They had evidently done what Paul had done (Acts 22:16). Those names — even though they are not mentioned — will shine forever while great names of the earth will fade into nothingness. (2) If you add to or take away from Bible (Rev. 22:18,19). (3) If you fail to overcome (Rev. 3:4,5). We have much to overcome and much to do to keep from being overcome (Rom. 12:21; II Pet. 2:20).

7. *This roll involves heaven and hell.* Rev. 20:14,15; 21:27.

THE ROLL UP YONDER

Lk. 10:20

1. *Introduction.* (1) Hymn: "When The Roll Is Called Up Yonder." (1) Having your name written in heaven is cause for great rejoicing (Lk. 10:20). (3) There is a roll or a book of life up yonder (Phil. 4:3).

2. *It is proper to keep a roll here on earth of the members of a congregation.* (1) The Jerusalem church members were counted (Acts 2:41). (2) It is as though the Lord went down the list of names in the church at Sardis when he said to them, "Thou hast a few names even in Sardis which have not defiled their garments" (Rev. 3:4).

(3) Elders are taught to be overseers of the congregation (Acts 20:28). It is easier to oversee them, if they have a list of the members. This promotes order, which is commanded (I Cor. 14:40).

3. *God provided for local churches*, and it is important that one be a member of a local church. (1) Paul or Saul saw this need, "And when Saul was come to Jerusalem, he assayed to join himself to the disciples" (Acts 9:26). He was already a member of the church. He merely joined himself to the local group of disciples. (2) The only organization in the church is that which is found in the local congregation. There is no organization in the church bigger than that (Acts 20:28; Heb. 13:17). (3) The local church is the only organization of the Lord to discipline members (Matt. 18:17). Beyond that there is no authority to act. (4) The gospel is to be made known by the local church (I Tim. 3:15). (5) The local church is a candlestick, a light bearer (Rev. 1:20; 2:5). (6) God has provided for the local church, so you should be a member of it.

4. *There is much misunderstanding relative to names on rolls*. (1) The fact that one's name has been added to a local church roll is no proof that God has added the person to the church. It is man's business to do the baptizing (Matt. 28:19,20), and it is God's business to do the adding to the church universal (Acts 2:47). This is wise, for only God knows the heart of the baptized. (2) The fact that brethren leave a name on the church roll here on earth is no proof that God is going to leave it on the roll up yonder. Names once entered in the roll up there can be erased (Rev. 3:5; 22:19). God is looking after this matter and will handle it properly regardless of man. (3) The important thing is to have your name on the roll up yonder (Phil. 4:3) and to keep it there (Rev. 3:5). But many think that if their name is on the church roll here on earth all is well with their souls no matter how they live. This is false security. (4) This false conception of rolls and letters seems to be increasing. I received a communication

from a lady in California who said, "I have been in California eighteen years, but during all these years I have left my letter at the Polytechnic Church of Christ, Fort Worth, Texas. I wish you would send it to me, please." We do not keep letters of the members. A letter is a recommendation; and of course we are happy to give such to a worthy Christian. Too often we hear, "I moved my letter" — well, what did he move?

RETURNING GOOD FOR EVIL

Matt. 5:43-47

1. *Introduction.* (1) This is one of the most difficult things in the Christian life. (2) The human way is: A. "An eye for an eye" (Matt. 5:38). B. "Love thy neighbor, and hate thine enemy" (Matt. 5:43). C. "Salute your brethren only" (Matt. 5:47).

2. *Other passages:* Rom. 12:17,20,21; I Pet. 3:9.

3. *Examples:* (1) Joseph blessed his brothers (Gen. 50:15-21; 45:1-8). (2) Hebrew maid blessed her captor (II Kings 5:1-4). (3) David spared Saul (I Sam. 24:9-15; 26). Saul was jealous of David (I Sam. 18:5-9) and became his enemy continually (I Sam. 18:29). (4) Christ prayed and died for his enemies (Lk. 23:34; Jno. 15:13). (5) Stephen prayed for his murderers (Acts 7:60).

4. This is the *spirit of a child* (Matt. 18:3; 19:14). You can whip a child and he will later come and throw his arms around you.

5. This is living by the *Golden Rule* (Matt. 7:12).

6. The Christian believes in letting the *Lord take vengeance* (Rom. 12:19).

7. The Christian believes in *doing good unto all men*, even his enemies (Gal. 6:10). If this were followed by all men, there would be no murders, no spite work, no discord — nothing but good will.

8. *This is the best way to live.* (1) In the first place it would be difficult to pay back some people like for like;

you just cannot get that mean; you would be sure to lose.
 (2) Christ's way brings peace and happiness. But he who lives by the other rule has bitterness and misery.

“LOOK WHAT YOU MADE ME DO”

1. *Introduction.* Children frequently say this. They start out early to put the blame on somebody else. A mother rebuked her little daughter for making faces at a bulldog. She replied, “Well, he started it.”

2. *Adam* tried to blame *Eve*, and *Eve* tried to blame the serpent (Gen. 3:12,13).

3. *Aaron* sought to put the responsibility of his sins on the people and on the fire (Ex. 32:22,24).

4. *You have heard this:* “When I was a little boy they made me go to church all the time, so when I got older I quit the church” — “Look what they made me do.” (1) Did they make you bathe and comb your hair? Have you quit these, too? (2) Should be grateful for such parents. Eph. 6:4.

5. *A song leader* was told by an elder that they would like for another man to lead singing that day. He became very angry and quit the church. He says that this elder caused him to quit. (1) Elders have the right to oversee the church (Acts 20:28). (2) There are no permanent positions in the church. (3) Selfishness was the cause. (4) If we are not in fellowship with the brethren, we are not walking in the light (I Jno. 1:7).

6. *A business man* drinks for business and social reasons and then says, “If they had not put it out there and insisted, I would not have done it” — “They made me do it.” Rom. 12:21; Col. 4:5; Matt. 5:16.

7. *One may get angry*, lose his temper, and take the name of God in vain, and later say, “You caused me to.” (1) There is no honor in holding your temper, if there is never an occasion to turn it loose. (2) Eph. 4:26; Ex. 20:7.

8. *We hear this:* "I got sick and they didn't visit me; so I quit the church" — "Look what they made me do." (1) The Bible talks about the sick calling for members to visit them (Jas. 5:14). Did you do this? (2) Have you visited other members of the church when they were sick? (3) We are not to go to church to be served, but to serve (Matt. 20:28). Did you do this?

9. *When the church is criticized,* some members, rather than defend it, join in the criticism, saying, "Well, there are a lot of things up there I don't like either, etc." They later say, "I wouldn't have done it, if others hadn't done it first" — "They made me do it." (1) They lack courage. (2) Eph. 6:10,11; Phil. 1:17; Jude 3.

10. *This is a time-worn statement:* "They weren't friendly, so I quit the church" — "See how awful they were." (1) This is as much your responsibility as the other fellow's (Prov. 18:24). (2) We go to church to worship and serve God, not just to be friendly (Jno. 4:23,24).

11. *Backsliders* often speak these trite words: "They just asked for money all time, so I quit" — in other words, "Look what they made me do." (1) Have you quit America because they ask for money (taxes) all the time? What about the stores and filling stations? (2) Money is a scriptural topic (I Cor. 16:2), but many are sensitive about it.

12. *Glory-seekers have said,* "They wouldn't call on me often enough, so I quit" — "They made me do it; if they had called on me oftener, I would still be in." (1) Why were you going to church? Just to be before the people? Matt. 23:5. (2) Must learn to follow as well as lead.

13. *Some young people* become worldly and quit the church. Parents say, "I can't blame them, because the church didn't furnish any recreation or entertainment for them." Well, what did you do to supply that need? They are your children. Eph. 6:4.

14. *An elder* wondered how the church would get

along without him, so he absented himself one Sunday. Because they got along all right he became angry and quit. In other words, "They caused me to, because they didn't miss me." (1) One should not be so puffed up — be humble (Jas. 4:10). (2) Whether we are missed or not, we have an obligation to God (Rom. 14:12).

15. *Some say*, "The preacher preached to me, so I'm not going back any more" — "Look what he made me do." What is a preacher supposed to do? Preach against sin? "Oh! Yes! Provided he doesn't specify any of mine." II Tim. 4:1-4.

16. But it still remains that *each will have to answer for himself*. Jno. 12:48; Rom. 2:6; Rev. 20:12.

REASONS FOR DOING MISSIONARY WORK

1. *The mission of Christ* to this world should stir us to do missionary work. (1) He came to save the lost (Lk. 19:10; Jno. 3:17; Matt. 26:28). (2) He is our example (I Pet. 2:21).

2. *The second great commandment* of the law demands it (Matt. 22:39). A man with a lumberyard on the flood-swollen banks of a river refused to throw in a plank for the salvation of his neighbors until it was paid for. This is inhuman. Likewise our hearts should go out to those who are being swept away by the floods of sin.

3. *The Golden Rule* requires it (Matt. 7:12).

4. *The gospel* is the only thing that can save (Rom. 1:16; II Thess. 1:8,9). If we sit back and wait for something else to save them, they will perish.

5. *God's plan of salvation* demands it. (1) The parable of the sower gives the three essentials to the production of gospel fruit (Matt. 13:3-8, 18-23). A. Seed (Lk. 8:11; Jas. 1:21). B. Soil (Lk. 8:15). C. Sower (Matt. 13:3). (2) No one can call on the Lord who has not believed, and no one can believe who has not heard (Rom. 10:13,14). (3) This is the Lord's arrangement: teaching, understanding, conversion, and forgiveness (Matt. 13:15).

6. *It is a command of God to preach the gospel to all the world* (Mk. 16:15,16; Matt. 28:19,20). No one individual can do this, but that does not excuse each from doing what he can.

7. *The greatest work of the church requires it — preaching the gospel.* (1) It is to be made known by the church (Eph. 3:21). (2) The church is the pillar and ground of the truth (I Tim. 3:15).

8. *The duty of the church to save others is impressed upon us by the example of the church in the apostolic age.* (1) Church at Jerusalem (Acts 8:4). (2) Church at Philippi (Phil. 4:15).

9. *The instructions on prayer require us to do missionary work* (Matt. 9:37,38). But praying for it and doing nothing about it would be about like praying for bread without working. Faith without works is dead (Jas. 2:17).

ARE YOU READY?

1. Peter said, "*Lord, I am ready to go with thee, both into prison, and to death*" (Lk. 22:33) — wherever he led him. (1) But he was not ready. He just thought he was. He later denied the Lord (Lk. 22:55-62). (2) We should follow Jesus, for he is our example (I Pet. 2:21). Our following him necessitates self-denial (Matt. 16:24). But even a dog will follow his master. (3) Our following Jesus is like a sailor sailing under sealed orders. The question of obedience has been settled before the orders are read.

2. "*Be ready always to give an answer to every man that asketh you a reason of the hope that is in you, with meekness and fear*" (I Pet. 3:15). (1) It takes study to do this (II Tim. 2:15; 4:13). (2) It also takes the right disposition of heart to do it in the manner commanded. One might win a discussion and lose a soul. Let us win the soul as well as the discussion. "He that winneth souls is wise" (Prov. 11:30).

3. Paul said, "*I am ready to preach the gospel*" (Rom. 1:16). (1) Why? He believed it to be the power of God unto salvation (Rom. 1:16). He was not ashamed of the gospel (Rom. 1:16). He recognized that he was a debtor (Rom. 1:14). (2) These same reasons will also motivate us to preach the gospel.

4. "*That they . . . be . . . ready to distribute*" (I Tim. 6:18). (1) Sharing with others is a Christian principle of life. God even shared his Son with us. (2) This indicates unselfishness and kindness. It was a mark of the early church (Acts 2:45; 4:34,35). A religion without a heart is worthless.

5. We should "*be ready to every good work*" (Tit. 3:1). (1) Be ready to do it yourself. Do not wish it off on somebody else. (2) Works are the fruits of faith, for we show our faith by our works (Jas. 2:18). (3) This kind of religion is known, for a tree is known by its fruits (Lk. 6:44).

6. Paul said, "*I am ready . . . to die . . . for the name of the Lord Jesus*" (Acts 21:13). (1) The statement was correct, for later he did die for Jesus. Just prior to his death he wrote some very dramatic words which are found in II Tim. 4:6-8. (2) Does the Lord mean that much to us? We are not called upon to die for him, but we are asked to live for him (Rom. 12:1).

7. Jesus has commanded us to *be ready for his return* (Matt. 24:42-44). (1) The tragedy of the foolish virgins was that they were not ready to meet the bridegroom (Matt. 25:1-13). (2) To be ready one must be in the kingdom and make preparation as did the wise virgins. This preparation does not come accidentally. You have to make it on purpose.

8. *Conclusion.* Victories are won by being ready. An old Greek officer counseled the generals on the eve of an engagement: "The secret of victory is in getting a good ready." In keeping with this, General Foch said, "Battles are won the day before." We need the "day-before" preparation that we may be ready.

MISTAKES OF "SUCCESSFUL" MEN

1. *Introduction.* We have put "successful" in quotation marks, because these men were successful only from the world's viewpoint.

2. *Solomon.* He was a powerful king to which other nations were content to pay annual tribute, exceedingly wealthy, and the wisest man of all ages (II Chron. 9). His great mistake was the marrying of heathen women (I Kings 11:1-10). They turned away his heart after other gods. Marrying out of the church has led many in recent years to the same unhappy and galling penalty.

3. *Samson.* He was a war hero (Judges 15); he was a strong man physically, but he was a weakling in the field of love and courtship. His downfall came as the result of loving and trusting an unworthy woman (Judges 16).

4. *Rich young ruler* (Matt. 19:16-22). He was rich, religious, and young. The world was proud of him. His big blunder was that he loved material wealth more than the Lord. I Tim. 6:9,10.

5. *The rich man whose barns overflowed* (Lk. 12:16-21). He was a successful farmer; he was thrifty; he was visionary. Surely his community was proud of him. But he was a fool. Why? His grievous mistake was that he laid up treasure for himself and was not rich toward God. Matt. 6:19,20; Mk. 8:36,37.

6. *The rich man mentioned in the story with Lazarus* (Lk. 16:19-31). No doubt he was the pride of the community and the envy of many; he was "clothed in purple and fine linen"; he "fared sumptuously every day"; the poor desired the crumbs which fell from his table; he was a big man. But his success was short lived. Why? He missed heaven. He made the mistake of neglecting his soul. Heb. 2:3.

7. *Judas Iscariot.* He had the honor of being selected as one of the twelve apostles. Furthermore, he was chosen to be the treasurer (Jno. 12:6); he was loved, admired, and respected. What blighted his success and killed his hopes? He made the great mistake of allowing Satan to

enter into his heart (Luke 22:3). Satan is too dangerous to entertain. Then Judas turned traitor for thirty pieces of silver (Matt. 26:14-16). He later became a suicide (Matt. 27:3-5).

8. *Pontius Pilate* (Matt. 27). He was the Roman governor of Judaea. He had power and prestige. According to the standards of the world, he was a great success. But he blundered miserably! He made the mistake of yielding to public favor against his convictions. This is always a mistake. This "successful" man's name has gone down into the records of time as a moral coward.

9. *Worldly success*. I have read the following and it is reputed to be true:

In 1923, a very important meeting was held in the Edgewater Beach Hotel, in Chicago. Attending this meeting were ten of the world's most successful financiers. Those present were: the president of the largest independent steel company in the world, the president of the National City Bank, the president of the largest utility company, the greatest wheat speculator, the president of the New York Stock Exchange, a member of the president's cabinet, the greatest bear of Wall Street, head of the world's greatest monopoly, and the president of the Bank of International Settlement.

Twenty-five years later:

Charles Schwab, the president of the largest steel company, had died in bankrupt condition.

Sam Insull, president of largest utility company, had died as a fugitive from justice.

Howard Hobson, president of the largest gas company, was insane.

Arthur Cotton, greatest wheat speculator, had died abroad, insolvent.

Richard Whitney, president of the New York Stock Exchange, had just been released from Sing-Sing.

Albert Fall, member of the president's cabinet, was pardoned from prison so he could die at home.

Jesse Livermore, the greatest "bear" of Wall Street, had died a suicide.

Ivar Gruegar, head of the greatest monopoly, had also committed suicide.

Leon Fraser, president of the Bank of International Settlement, had likewise committed suicide.

Definition of success: "He has achieved success who has lived well . . . laughed often . . . and loved much. Who has gained the respect of intelligent men, and the love of little children; who accomplished his task; who has left the world better than he found it whether by an improved poppy or a perfect poem, or a rescued soul; who has never lacked appreciation of earth's beauty, or failed to express it; who has looked for the best in others . . . and given the best he had; whose life was an inspiration; whose memory, a benediction"; and who used life to prepare his soul for heaven. It is summed up in Eccl. 12:13.

10. *Conclusion.*

Let no one till his death
Be called unhappy. Measure not the work
Until the day's out and the labor done;
Then bring your gauges.

—Elizabeth Barrett Browning

LOST RELIGIOUS PEOPLE

1. *Introduction.* The Bible has much to say about lost religious people — religious, but religiously wrong.

2. *Pharisees* (Matt. 23). (1) Jesus called them a child of hell (Matt. 23:15). (2) Why were they lost? Said and did not (Matt. 23:3). Did works to be seen of men (Matt. 23:5). Shut up the kingdom of heaven against men (Matt. 23:13). For a pretense made long prayer (Matt. 23:14). Omitted the weightier matters of the law (Matt. 23:23). Strained at a gnat and swallowed a camel (Matt. 23:24). Outwardly appeared righteous to men, but within were full of hypocrisy (Matt. 23:28).

3. *Another Pharisee* (Lk. 18:9-14). (1) He prayed, fasted, gave tithes, and there were many evil things he did not do. (2) Why was he lost? Trusted in himself that he was righteous (Lk. 18:9). (3) Lk. 18:14; Prov. 3:5.

4. *Saul of Tarsus* (Acts 9, 22, 26). (1) Was very religious (Phil. 3:4-6). (2) Had a good conscience (Acts 23:1). (3) Had so much faith that he wanted to know

what to do (Acts 9:6). (4) Was penitent, so much that he fasted (Acts 9:9). (5) But he was still lost (Acts 22:16). Why? Religiously wrong; had not complied with the law of pardon.

5 *Eunuch* (Acts 8:25-39). (1) Had been to worship (Acts 8:27). One may worship unacceptably (Matt. 15:9). (2) Was a Bible-reading man (Acts 8:28). Why was he lost? Had not obeyed the plan of salvation.

6. *Cornelius* (Acts 10). (1) Was devout, feared God, gave much alms, and prayed to God always (Acts 10:2). (2) Why was he lost? Needed to hear words of salvation and obey them (Acts 11:14).

7. *Man given one talent* (Matt. 25:14-30). (1) Represents some in the kingdom or church (Matt. 25:14). (2) Why was he lost? Buried his talent.

8. *Five foolish virgins* (Matt. 25:1-13). (1) Portrays some in the kingdom or church. (2) Why were they lost? Were not ready; had not made enough preparation (Matt. 25:10).

9. *Church at Laodicea* (Rev. 3:14-22). Why lost? Lukewarm.

10. *Many religious people will be disappointed at the judgment* (Matt. 7:21-23).

SOME THINGS FOR CHRISTIANS TO REMEMBER

1. Remember: *We may be our worst enemies by opposing ourselves* (II Tim. 2:25). High temper. Long tongue. Spiteful. Unforgiving. Stubborn. Worldly.

2. Remember: *We should change our minds if we are wrong*. (1) Some people will never admit they are wrong about anything; however, to admit that we were wrong is to prove that we are wiser today than we were yesterday. To confess wrong is to admit one's humanity. Never to admit a wrong is to pose as divine, for only the Divine One never sins. (2) Paul changed (Acts 22:1-6; 26:9).

3. Remember: *Return good for evil*. (1) Matt. 5:43, 44; Rom. 12:20,21. (2) Example: The horse of a good

man strayed into the road. A neighbor put the animal in the public pound and said to its owner, "If I catch him in the road again, I'll do it again." The neighbor replied, "A week ago I saw your cattle in my meadow, and I drove them out and shut them in your pasture. If I ever catch them there again, I'll do it again." It so struck the man that he took the horse out of the pound and paid the charges.

4. Remember: *Do not blindly follow another.* (1) Matt. 15:14; Matt. 7:13,14. (2) Jesus is our example (I Cor. 11:1). (3) Illustration: One of the most famous epigraphs reads:

Stranger, stop as you pass by;
As you are now, so once was I.
As I am now, you soon will be;
And so prepare to follow me.

Someone reading this, and seriously considering the matter, wisely added two lines:

To follow you I'm not content,
Until I know which way you went.

5. Remember: *Satan is trying to get your soul.* He tempts (Matt. 4:1), lies (Jno. 8:44), steals the word (Lk. 8:12), persecutes (Rev. 2:10), fashions himself into an angel of light (II Cor. 11:14,15), and seeks to destroy (I Pet. 5:8).

6. Remember: *Staying away from the services and fellowship of God's people will cause you to become cold.* (1) Matt. 24:17; Rev. 3:15,16. (2) Example: Preacher called on a member who habitually absented himself from church services. The family was gathered around the fireplace. The preacher silently lifted a large red coal and laid it by itself on the hearth. He sat and silently looked at the coal. It gradually faded into a black mass, became lukewarm, and then became cold and dead. The man looked at the preacher and said, "You need not say a word; I see the point; I'll be there next Sunday."

7. Remember: *You must be coupled to Christ.* (1)

Paul was (Phil. 4:13; 1:21). (2) Example: Two travelers, who thought they were able to take care of themselves, entered a railway car and found seats. The porter looked in and asked them to go forward. "What is the matter with this coach?" they asked. With a grin he replied, "Nothing. Only it ain't coupled to anything that'll take you anywhere." That is the trouble with many in the church. They sit there and look nice. But they are not going to heaven, because they are not coupled to Christ. "Churchanity"! But no Christianity!

QUESTIONING THE CONVENTIONAL

1. *Introduction.* (1) Jesus did not fall in with the popular and accepted notions about him. (2) He often questioned and rebuked the accepted practices and doctrines of the world.

2. Early in life *Jesus broke with the conventional* (Lk. 2:41-52). (1) The conventional thing was to return with his parents. (2) Question (Lk. 2:49).

3. He questioned man's customary *anxiety about tomorrow* (Matt. 6:25-34). Question (Matt. 6:27).

4. He questioned the practice of *beholding the sins of others and seeing not your own.* (1) Question (Matt. 7:3). (2) If we hold a white sheet of paper with a black spot on it before an audience and ask them what they see, they will say, "A black spot." They never see all the white. This is true as we look at the lives of others. We see the black spots but not the white.

5. Our Lord questioned the accepted practice of *returning like for like* (Matt. 5:38-48). Question (Matt. 5:46).

6. He rebuked the Pharasaic practice of *parading religion to be seen of men* (Matt. 6:1-18). (1) Rebuke (Matt. 6:1). (2) Man said, "I didn't like your prayer this morning." Reply was, "The prayer was not prayed to you."

7. Jesus questioned the Jews' *refraining from doing good on the Sabbath* (Matt. 12:10-13). (1) Question (Matt.

12:11,12). (2) Some are so afraid they will do wrong that they refuse to do good.

8. He rebuked the practice of *wearing religious garb and religious titles* (Matt. 23:5-10). Why would one think it is pious to dress in somber robes?

9. He questioned the Jews' *supplanting the commands of God with tradition* (Matt. 15:1-9). Question (Matt. 15:3). Tradition hinders obedience to truth today.

10. Jesus rebuked the *world's standard of greatness* (Matt. 18:1-4). (1) What he did was a rebuke to the disciples. (2) Matt. 20:27.

ONWARD CHRISTIAN SOLDIERS

1. *Introduction*. For years Christians have marched onward singing the hymn, "Onward Christian Soldiers."

2. For an army to go forward, it must have a *good and capable captain*. Jesus is our captain (Heb. 2:10). (1) A captain in whom the soldiers have confidence is needed. Jesus meets the qualification. Paul said, "I know whom I have believed, and am persuaded that he is able to keep that which I have committed unto him against that day" (II Tim. 1:12). (2) We need a captain who takes the lead and commands soldiers to follow. Jesus does (I Pet. 2:21).

3. For an army to go forward, it is necessary that it have *good soldiers*. (1) Paul commanded Timothy to be a good soldier (II Tim. 2:3). (2) A good soldier is well disciplined; takes orders; obeys commands. Matt. 7:21-23; 6:10; Heb. 5:8,9. (3) A good soldier is willing to sacrifice. Paul said, "Neither count I my life dear unto myself" (Acts 20:24). Rom. 12:1. (4) A strong soldier stands steadfastly. Steadfastness is essential to success in every endeavor. Acts 2:42; I Cor. 15:58; 16:13. (5) A trustworthy soldier will not fraternize with the enemy; it is dangerous. We are commanded to "mark them which cause divisions and offenses contrary to the doctrine which ye have learned; and avoid them" (Rom. 16:17). II Jno.

9-11. (6) A good soldier is faithful unto death. Rev. 2:10.

An illustration written in blood is found in Texas history. During the War of Texas Independence — a war between Texas and Mexico — the 182 defenders of the Alamo were besieged by the army of General Santa Anna, President of Mexico. They faced surrender at discretion or certain death. On March 3, 1836, Col. Travis unsheathed his sword and drew a line on the stone floor, saying, "There is still time to escape! Let those who choose to stay and die with me step across this line." As the men surged across the line, a weak voice called out from a little room in the barracks from the sick Bowie, "Some of you come and lift me across." A storm of cheers went up as four soldiers carried Bowie's cot across the line. Only one failed to step across that line. He left that night under cover of darkness. The rest of them died to the man — and so did 1500 Mexicans. In their defeat, they won. Their heroism became the battlecry of the war. "Remember the Alamo!"

4. To go onward, an army must have *adequate equipment*. The Christian soldier is well equipped when he puts on the divine armor (Eph. 6:11-17): (1) "Your loins girt about with truth." Deceit will not do. Error will not suffice. Jno. 8:32; II Thess. 2:10-12. (2) "Having on the breastplate of righteousness." Man becomes righteous by doing the will of God (Lk. 1:6). This protects him from the darts of the enemy. (3) "Your feet shod with the preparation of the gospel of peace." Must have a protected foothold. The thought here is preparedness. The Christian must be ready (I Pet. 3:15). (4) "Taking the shield of faith." Faith in God becomes the shield that protects us from the darts of the wicked. Gal. 2:20; Psa. 27:13. (5) "Take the helmet of salvation." Scriptural assurance of salvation protects the Christian and encourages him to fight with confidence and joy. Rom. 8:16; I Jno. 2:3. (6) "And the sword of the Spirit." This is the word of God. It is "sharper than any two-edged sword" (Heb. 4:12). It was given to prick and cut hearts

(Acts 2:37; 7:54) — not to spread butter. It serves as both a defensive and offensive weapon.

5. For an army to go onward, it *must be on the lookout for spies*. (1) False brethren crept in unawares on Paul's day to spy out his liberty in Christ (Gal. 2:4). (2) Satan is transformed into an angel of light and so are his servants (II Cor. 11:14,15). (3) The Lord warns us against false teachers (II Pet. 2:1-3).

6. To go onward, an army must be so *faithful and indoctrinated* that it cannot be weakened by the enemy's propaganda. The shallow and immature Christians are a ready prey to false teachers (Gal. 1:6,7). Eph. 4:14.

7. An army must be *united*, if it would go forward. (1) Every soldier must supply his part (Eph. 4:16). (2) Eph. 4:3; I Cor. 1:10. (3) A divided army will destroy itself (Gal. 5:15); it cannot stand (Matt. 12:25).

“IF ANY MAN WILL COME AFTER ME”

1. *Introduction*. Let us study each phrase in the text.

2. “*If any man will.*” (1) Following the Lord is a matter of choice, as seen in the phrase. Josh. 24:15; Acts 2:40. If a man can obey, then he can disobey. So man's ability to do right necessitates his ability to do wrong. The elements obey the Lord without choice (II Pet. 3:7; Matt. 8:27). But no person wishes to be a star in the sky! He likes being a man created in the image of God, having the power of volition (Gen. 1:26,27). (2) God, Christ, and the Holy Spirit plead for man to make the right choice (I Tim. 2:3,4; Matt. 11:28-30; Rev. 22:17). (3) If man is lost, it is because he has willed it that way (Matt. 23:37; Acts 13:46).

3. “*Come after me.*” (1) Many are following the wrong one — man (I Cor. 1:12,13; Gal. 1:16), and the wrong thing — man's doctrine (Matt. 15:9). (2) Should follow Christ (I Pet. 2:21; I Cor. 11:1). (3) Should follow Christ for salvation (Jno. 14:6). He has been over

the road from earth to heaven. He is an authority on the subject (Matt. 28:20). Why follow some man who has not been over the road? (4) Should follow Christ's word (Jno. 12:48; Heb. 1:1,2). (5) Should be in Christ's church (Acts 2:47; Matt. 15:13,14). (6) Should wear Christ's name (Acts 11:26; I Pet. 4:16).

4. "*Let him deny himself.*" (1) It means let him surrender to God his will, his affections, his body, and his soul. Let him not seek his own happiness as the supreme object. (2) Deny self (Matt. 18:8,9; Jas. 1:27). (3) Love God more than pleasure (I Tim. 5:6). (4) Be different from the world (Rom. 12:2). (5) Paul is an encouraging example of self-denial (Phil. 3:4-8).

5. "*And take up his cross.*" (1) Persons condemned to be crucified were compelled to bear the cross on which they were to be crucified to the place of execution. Such was an addition to the punishment; it was burdensome and disgraceful. "Take up his cross" is a figurative statement, denoting that we must endure whatever is burdensome or trying in following Christ. (2) In the booklet, *The Cross-bearer*, the author pictures one man dragging the cross behind him. He wishes to have the benefits of cross-bearing, but is ashamed of the cross. Another is pictured sawing off a part of the cross. He, too, likes the blessings derived from cross-bearing, but he thinks the cross of Christ is too burdensome. He attempts to change the cross to fit himself rather than change himself to fit the cross; this is the great sin in religion. However, another is pictured bearing the cross and keeping pace with Christ; he is the true cross-bearer. (3) Paul is an inspiring example as a true cross-bearer (II Cor. 11:24-28).

6. "*And follow me.*" Following Jesus leads to baptism (Matt. 3:13-17), resistance to temptation (Matt. 4:1-11), worship (Lk. 4:16), sacrifice (Jno. 10:18), prayer (Lk. 6:12), goodness toward others (Matt. 7:12; Lk. 23:34), and heaven (Jno. 14:1-4). To go to heaven, we must follow Christ's steps; they lead there.

WHAT ABOUT REINCARNATION?

1. *Introduction.* (1) Definition: "The belief that the souls of the dead successively return to earth in new forms or bodies." (2) This is a basic doctrine of Mohammedanism. (3) Time is ripe when someone may start a new church with this unscriptural doctrine as a basis. (4) You may think the doctrine is too ridiculous to consider. Alexander Campbell felt the same way in his day about Mormonism. He said, "Mormonism is too ridiculous to consider." Yet Mormonism has grown rapidly.

2. *The Bible never speaks of reincarnation; therefore, there can be no faith in it* (Rom. 10:17).

3. "It is appointed unto men *once to die*" (Heb. 9:27) — "once," not several times.

4. "A *time* to be born, and a *time* to die" (Eccl. 3:2) — "a *time*," not several times.

5. "For that shall abide with him of his labor *the days of his life*, which God giveth him under the sun" (Eccl. 8:15) — "life . . . under the sun," singular, not many lives.

6. "Then shall the dust return to the earth as it was: and *the spirit shall return unto God* who gave it" (Eccl. 12:7) — not enter into another body. Also, II Cor. 5:1.

7. Solomon emphasized that *now in this life* — not in other lives — is the time to labor for a reward (Eccl. 9:3,5,6,7,10). This aspect of man's relationship to God has not changed since Solomon's day.

8. God will bring man into judgment for *what he has done in this life* (Eccl. 11:9; Rom. 2:6; Gal. 6:7,8). "For we must all appear before the judgment seat of Christ; that every one may receive the things done in his body [not bodies] according to that he hath done, whether it be good or bad" (II Cor. 5:10).

9. "The imagination of man's heart is evil *from his youth*" (Gen. 8:21). But if the doctrine of reincarnation is true, man is evil at birth, because he has lived before.

10. God permitted Moses and Elias to appear on earth again (Matt. 17:1-5), *but not as other people*; and that ap-

pearance was only temporary and for the purpose of teaching a lesson.

11. In Lk. 16:19-31 we have the story of the death and destination of two men, and *neither was reincarnated*.

ALMOST

1. "*Almost thou persuadest me to be a Christian*" (Acts 26:28). (1) This was said by Agrippa, who came close to pardon only to miss it. This is true of many. (2) Felix is another example of being almost persuaded (Acts 24:25). (3) Author was asked to conduct funeral for man who had almost been persuaded to be a Christian. All the wife could say to me was, "Do the best you can." (4) Paul was not trying to persuade Agrippa to be a sectarian — but a Christian only (Acts 26:28). Acts 11:26; I Pet. 4:16.

2. "But as for me, *my feet were almost gone; my steps had well-nigh slipped*" (Psa. 73:2). (1) "Backsliding" is a Biblical expression and is used about fifteen times. Jeremiah used it twelve times to describe the condition of Israel. (2) It is a real condition — not imaginary. Matt. 24:12; Jno. 6:66; Gal. 5:7; Lk. 9:62; Matt. 5:13; II Pet. 2:20-22. (3) Why do they slip? A. Doubts. The Psalmist envied the world and doubted (Psa. 73:2,3). Psa. 27:13; Heb. 3:12. B. Evil associates (I Cor. 5:6; 15:33). C. Love of the world (II Tim. 4:10). I Jno. 2:15-17; Jas 4:4. D. Fail to go forward (Phil. 3:13,14). Example: The Christian life is like riding a bicycle; if you do not go on, you go off. Another example: A little boy fell out of bed. His mother asked him why he fell out. "I don't know," he replied, "unless I went to sleep too near where I got in." This is the tragedy of many Christian lives. E. Cares of the world (Matt. 13:22). F. Discouragement due to illness or domestic or financial problems; think they are not going to heaven any way; not put to work. (4) If your feet have slipped; A. Do as David — consider the ways and words of God (Psa. 73:17-28). B.

You also need to repent, confess, and pray (Acts 8:22; Jas. 5:16).

TOMORROW

1. *Introduction.* There is no more dangerous word in human speech than this one, "tomorrow." The tragedy of it is that its real danger lies hidden and unrealized. It has robbed multitudes of success. It has slammed the gate of heaven in the face of millions.

2. "*Boast not thyself of tomorrow*" (Prov. 27:1). (1) Tomorrow you may lose your desire to do your duty; your conscience may become seared (I Tim. 4:2). A Texas farmer, a Christian, a poor man, showed emotion because he was unable to give more into the treasury of the church. He became very rich from oil. Later he continued to show signs of emotional upset when sermons were preached on giving. His explanation was: "Back then I had the desire to give, but did not have the means; now I have the means, but I have lost my desire." (2) Tomorrow may see man incapable of doing his duties because of sickness and other reasons. (3) Tomorrow may bring death (Jas. 4:13,14). Job. 14:1,2. There are some eighteen or more metaphors in the Bible which express the brevity and uncertainty of life, such as: "the shadow that fleeth," "a flower that is cut down," "the weaver's shuttle," "water spilt on the ground," "the swift ship," and "a vapor." (4) Tomorrow may bring the judgment (Matt. 25:13,32; Rom. 14:10,12).

Tomorrow, and tomorrow, and tomorrow,
 Creeps in this petty pace from day to day,
 To the last syllable of recorded time;
 And all our yesterdays have lighted fools
 the way to dusty death.

—Macbeth, Shakespeare

3. *Absalom*, who rebelled against his father, *was defeated because he waited until tomorrow* (II Sam. 15:18).

The same tomorrow kept Hitler from conquering Europe in World War II. He had his chance following Dunkirk, but he waited until tomorrow.

4. *In the parable of the Great Supper*, there are great lessons on tomorrow (Lk. 14:16-24). (1) One said, "I have bought a piece of ground, and I must needs go and see it" — wait until tomorrow. (2) The second said, "I have bought five yoke of oxen, and I go to prove them" — excuse me; wait until tomorrow. (3) Jesus is saying, "Come; for all things are now ready" (Lk. 14:17).

5. *The spirit of tomorrow caused the ruin of the foolish virgins* (Matt. 25:1-12). The Christian religion is a daily religion (Heb. 3:13). We must prepare and be prepared every day (Matt. 25:13).

6. *Tomorrow in the life of Felix* (Acts 24:24-27). He heard a soul-stirring sermon on righteousness when he was unrighteous, on temperance when he was intemperate, and on the judgment to come even though he sat in judgment on others. He trembled. But he refused to surrender. He waited for the convenient season on tomorrow which did not come. He often called for Paul, but the preaching never again had the same effect.

7. *The rich fool had great plans for tomorrow* (Lk. 12:16-21). He failed to realize that God controls tomorrow. One word tells the tragedy of his life — tomorrow.

8. *The young man who said to Jesus, "Tomorrow"* (Matt. 8:21,22). He felt that all personal and business matters were to be attended to today. But following Jesus was to wait until tomorrow. Matt. 6:33.

9. *The great word in the Bible is always "Today."* Heb. 3:13,7,8; II Cor. 6:2; Jno. 9:4.

10. *Many are waiting until tomorrow* to do what should be done today: to obey the gospel, to be restored, to live the Christian life, to bring up children properly, etc.

He was going to be all that a mortal should be
 Tomorrow
 No one would be better than he
 Tomorrow
 Each morning he stacked up the letters he'd write
 Tomorrow
 It was too bad indeed he was too busy to see Bill, but
 he promised to do it
 Tomorrow
 The greatest of workers this man would have been
 Tomorrow
 The world would have known him had he ever seen
 Tomorrow
 But the fact is he died and faded from view, and all
 that was left when living was through
 Was a mountain of things he intended to do
 Tomorrow

—Author Unknown

WHAT AN HONOR TO BE CALLED "CHICKEN"

1. *Introduction.* (1) Both Jesus and Paul used common, everyday illustrations and terms. This lesson is especially for young people, but also is of value to older ones. (2) The term "chicken" is used to belittle and slur as a weakling one who refuses to fall in line with the crowd. (3) Takes real strength to stand for convictions against the crowd. Takes more strength and manhood to be a Christian than it does to be anything else.

2. *Scriptures.* (1) Ex. 23:2; Matt. 7:13,14; Rom. 12:2,21; Matt. 5:11,12; Matt. 10:28. (2) In all seven letters to the churches in Asia, Jesus emphasized overcoming — "To him that overcometh" (Rev. 3:21). (3) Shakespeare: "To thine own self be true, and it must follow as the night the day, thou canst not then be false to any man."

3. *Some who were too weak to say "no."* (1) Adam (Gen. 3:1-6). He was a great lexicographer — gave names to birds and beasts — but could not say "no." In substance the serpent said, "Go on and eat — don't be 'chicken'." It took less strength to eat than it did to refuse; so they followed the course of least resistance. (2) Demas

(II Tim. 4:10). The world said, "Everybody else is living this way; enjoy yourself; Demas, don't be 'chicken'." He knew better; he showed weakness. Jas. 4:4. (3) Pilate (Matt. 27:15-24). He was afraid some would say "Pilate is 'chicken'." His wife tried to get him to hear another voice — that of right. Everybody has someone who is trying to get him to hear the voice of right — mother, father, teacher, or friend.

4. *Some who were strong enough to go against a "chicken-crowd" of weaklings.* (1) Vashti (Esther 1). She was asked to expose herself to a drunken crowd. Her "no" meant dethronement and banishment. No doubt, some said, "Go ahead, Vashti; don't be 'chicken'!" She counted the cost and refused. She was not "chicken." I Tim. 2:9. (2) Shadrach, Meshach, Abednego. They chose to burn rather than bow down to a heathen god (Dan. 3:4-6, 17,18). They were not "chicken." (3) Jesus (Matt. 4:1-11). He said "no" to Satan. It took much strength. He was not "chicken."

5. *Conclusion.* Young people, say "no" to the temptations of self, of others, and of the world. Deny thyself (Matt. 16:24). Are you going to be just a drifter? a weak "yes" man? It is not "chicken" to say "no." It shows strong character.

"NOTS" WHICH CANNOT BE UNTIED

1. *Introduction.* We are making a little play on words. The "nots" we are studying are negatives. God put certain "nots," or negatives, in the Bible. They cannot be untied, loosed, or taken out of the Scriptures. They are there to stay (Matt. 24:35). We cannot change God's order (Deut. 4:2; Rev. 22:18,19). We cannot untie what God has tied.

2. "Ye see then how that by works a man is justified, and *not by faith only*" (Jas. 2:24). (1) The little word "not" refutes the human doctrine of salvation by faith only. Other verses in the chapter — 17,19,26 — further

prove it. (2) Man is justified by faith (Rom. 5:1), walks by faith (II Cor. 5:7), lives by faith (Gal. 2:20), and is saved by faith (Acts 16:31) — but not by faith only. Then how is he saved by faith? Answer: when that faith obeys (Heb. 11:30; Josh. 6; Gal. 5:6).

3. "For by grace are ye saved through faith; and that *not of yourselves*: it is the gift of God; *not of works*, lest any man should boast" (Eph. 2:8,9). (1) "Not of yourselves" — yet Peter said, "Save yourselves" (Acts 2:40). "Not of works" — yet James said, "By works a man is justified" (Jas. 2:24). Does the Bible contradict itself? Certainly not! What is the explanation? (2) The "works" mentioned in Eph. 2:8,9 are the inventions and devices of men. Such does not save; if so, man could boast. The "works" mentioned in Jas. 2:4 are the appointments of God. When man does such works, he has not done his own works, but God's works. He is then saved — not by the merit of the works, but by the faith exercised in doing them. (3) "Not of works" rebukes the contention that man can be saved by morality alone. If so, he could be saved without faith (Heb. 11:6), without obedience to the gospel (Rom. 1:16; II Thess. 1:8,9), and out of the church (Eph. 2:16; 5:23).

4. "*Not everyone that saith unto me, Lord, Lord, shall enter into the kingdom of heaven; but he that doeth the will of my Father which is in heaven*" (Matt. 7:21). (1) This "not" refutes the contention that everyone who says, "Lord, Lord," will be saved. (2) Man must do more than acknowledge Christ's Lordship; must do more than believe; must be more than just religious; he must do the Father's will (Heb. 5:9).

5. "For we walk by faith, *not by sight*" (II Cor. 5:7). (1) Many claim they have seen miraculous evidences to prove their relationship to the Lord, but this "not" teaches otherwise. (2) The Christian religion is a religion of faith and faith comes from the word of God (Jno. 20:30,31; Rom. 10:17).

6. "*Buy the truth and sell it not*" (Prov. 23:23).

(1) Truth is a precious soul-saving commodity (Jno. 8:32; I Pet. 1:22). (2) Under no circumstances are we permitted to sell it — not for business, diplomacy, popularity, or peace in the family. Put a “not for sale” sign on it.

7. “*And be not conformed to this world*” (Rom. 12:2). (1) This “not” rebukes worldliness in the lives of Christians. The popularity of it — “Everybody else is doing it” — has no power to untie this “not” in the Scriptures. (2) Other passages (I Jno. 2:15-17; Jas. 4:4; Matt. 6:24).

8. “*Not forsaking the assembling of ourselves together*” (Heb. 10:25). (1) Some church members take this “not” out, and for the least little excuse. Neither rest nor recreation is a substitute for worship. (2) The early Christians assembled on the first day of the week (Acts 20:7; I Cor. 16:2).

9. “*But he answered and said, Verily I say unto you, I know you not*” (Matt. 25:12). (1) This “not” makes the passage forever read that Christ will not know the ones at the judgment who have failed to make enough preparation. The foolish virgins had made some preparation, but not enough. Phil. 2:12; I Cor. 10:12.

WORSHIP

1. *Introduction.* (1) Definition: “Honor, reverence, homage, in thought, feeling, or act.” (2) The principal Old Testament word is “shahah,” “depress, bow down, prostrate” as in Ex. 4:31. (3) The principal New Testament word is “proskuneo,” “kiss the hand or the ground toward,” hence often in the oriental fashion bowing prostrate upon the ground. (4) There is no more beautiful picture than true worship.

2. *The importance and necessity of worship.* (1) One of the first things mentioned in the Bible is worship — that of Cain and Abel (Gen. 4). (2) The first thing Noah did when he left the ark was to build an altar unto the Lord and worship (Gen. 8:20). (3) Psa 29:2. (4)

Psa. 95:6. (5) Wise men went to worship Jesus (Matt. 2:2). (6) Matt. 4:10. (7) Jesus left the example of worship for us (Lk. 4:16). (8) One must be a worshiper of God for his prayers to be answered (Jno. 9:31).

3. *The Lord's day is a special day for worship.* (1) Lord's day (Rev. 1:10) — because this is the day the Lord came forth from the tomb. Hence, we celebrate his resurrection every week. (2) Acts 20:7; I Cor. 16:2; Heb. 10:25. (3) However, the church in Jerusalem evidently had services on other days, because they had additions daily (Acts 2:47). Jesus taught daily (Matt. 26:55). It does not make sense to say that you worship the Lord on Sunday because you love him, but that you have no love for him on other days. (4) Some say, "I can get closer to God on the lake than I can in a church building." If so, I guess we are going to have to build all our church buildings on the side of the lake, because we are commanded to meet for worship. How can one get closer to God by disobeying him? Recreation is no substitute for worship.

4. *Things which hinder acceptable worship.* (1) No heart in it (Matt. 15:8). Not in spirit (Jno. 4:23,24). Mind is occupied with other things. Or you may have come in the role of a spectator and critic. (2) Not according to truth (Jno. 4:23,24). Jno. 17:17; Matt. 15:9. God has the right to prescribe the worship he wishes. Some worship partly in truth, but partly in error. A little poison will ruin a glass of milk. (3) Serving the devil nullifies worship (Matt. 4:8-10). Cannot serve God and Satan at the same time (Matt. 6:24; 12:30). (4) Lack of faith renders worship vain (Ex. 4:31). Do not have enough faith to worship regularly. Say "I attend worship pretty regularly." That means you miss the worship pretty regularly. (5) Lack of humility hindered the worship of the Pharisee (Lk. 18:10-14). God hates a proud look (Prov. 6:16-19). (6) Wrong attitude toward a brother (Matt. 5:23,24). Matt. 18:15-17. If a certain brother leads singing, some won't sing; or leads

prayer, some won't bow; or passes the contribution plates, some won't give; or passes the communion, some move to the other side — they might as well have stayed at home. (7) Robbery of God (Mal. 3:8,9). No person can worship acceptably and rob God in the same service. I Cor. 16:2; II Cor. 8:5. (8) Lack of reverence (I Cor. 11:27, 29). If it is in spirit, it will be in reverence.

“GIVE US SOMETHING PRACTICAL”

1. *Introduction.* (1) We hear this statement relative to teaching and preaching. Any expressed thought — good or bad — is likely to be repeated many times, because most people do not think for themselves. They are merely led by others. (2) The statement is being used in an effort to get away from the doctrinal and fundamental items of the faith. Its usage spells danger.

2. *The meaning of “practical.”* (1) Definition: that which is capable of being turned to use or account, usable. (2) There is a practicality in every Scripture (II Tim. 3:16,17). One verse may be more practical at a particular time for one person than for another, but every verse is practical.

3. *Some think doctrinal topics are not very practical.* God thought otherwise; for instance: (1) False doctrine renders worship vain (Matt. 15:9); so true doctrine is practical. (2) False doctrine keeps one from having God (II Jno. 9); so true doctrine is practical. (3) If one must take heed to doctrine to save himself and others (I Tim. 4:16), then it is practical. (4) If adding to or subtracting from the Bible will cause a man to be lost (Rev. 22:18,19), then sticking to the Bible is practical. (5) If your child is indoctrinated so that he will not be blown aside by false doctrine, then he has been given something practical (I Cor. 16:13; Jude 3). (6) If new converts, young or old, are so taught that the church will not apostatize, then something practical has been given. Apostasy begins with an attitude (II Tim. 4:3,4).

4. Even though you already know a thing, *it is still practical to hear it again*. (1) Hearing it stirs up the mind (II Pet. 3:1,2). (2) It feeds the soul (II Pet. 2:2). (3) This enables one to learn a lesson well enough to teach it to others (II Tim. 2:2; Heb. 5:12).

5. *Teaching souls to be saved is the most practical thing in the world*. (1) Matt. 28:19,20. (2) Even though you know those truths, you should rejoice when others are learning them. (3) You do not grow tired of hearing that you love; for instance, child climbs into your lap and says, "Daddy, I love you." (4) If you love truth, you rejoice to hear error rebuked (Psa. 97:10).

"HANDLE WITH CARE"

1. *Introduction*. (1) Many packages have these words stamped on them, "Handle With Care." These words also have an application to our souls. They too should be handled with care. (2) The soul has a journey to make (Gen. 35:18; Eccl. 12:7). The soul is too precious to neglect the watchwords, "Handle With Care." We do not want it delivered to the judgment battered and damaged.

2. *"Handle With Care" is proof the object is of value*. (1) The major reason for man's handling his soul with care is its value. (2) It is worth more than the world (Mk. 8:36,37). (3) It is worth so much that Jesus came into the world to save it (Matt. 1:21; Lk. 19:10). (4) It is so precious that God gave his Son in the behalf of it (Jno. 3:16; Rom. 5:8). (5) It is so valuable that Christ died for it (Isa. 53:5,6; I Cor. 15:3; I Pet. 2:24). (6) It is so dear that Jesus is now preparing heaven for it (Jno. 14:1-4).

3. *"Handle With Care" indicates that the object can be damaged or destroyed* — true of the soul. (1) The soul may be lost because of sin (Isa. 59:2; Jno. 8:21; Rev. 21:27). (2) The majority will be lost (Matt. 7:13, 14). (3) Matt. 25:41; Rev. 20:15.

4. "*Handle With Care*" are words of caution. (1) We should be cautious in handling the word of God (I Tim. 2:15; Jno. 5:39). (2) We should use caution in believing teachers and preachers (I Jno. 4:1). (3) We ought to be cautious in our living (Matt. 26:41; I Cor. 10:12).

5. *In spite of the value of the soul, many people are indifferent toward it.* (1) A few years ago Professor M. Brewster Smith of the Department of Psychology, Vassar College, made a survey of personal values. It was published in *The Journal of Psychology*. He chose a typical city of about 160,000 people, and selected a cross-section of the population. He asked these questions:

From your experience, what would you say are the most important things to you? What sort of things mean most to you? What things are you most interested in? What things do you care about most? Here are some of the results:

56% stated Economic Security.
 46% stated Home and Family life.
 25% stated Liberty and Freedom.
 13% stated World Peace.
 10% stated Education.
 8% stated Religion.
 4% stated Decency and Morality.
 2% stated Being a Good Citizen.

(2) The cold facts are that most people want material security more than they want God or liberty. Politicians have taken note of this, and have offered the people more and more of everything for less and less of nothing. (3) In a sermon against materialism Christ said, "A man's life consisteth not in the abundance of things which he possesseth" (Lk. 12:15). (4) Jesus teaches that security is first of all a spiritual rather than an economic matter (Matt. 6:33). (5) Most people's philosophy of life is summed up by the rich man who said, "And I will say to my soul, Soul . . . take thine ease" (Lk. 12:19).

6. *In handling the soul with care we look to Jesus as our example* (I Pet. 2:21; I Cor. 11:1). (1) He was

about the Father's business at an early age (Lk. 2:49). (2) He was baptized to fulfil all righteousness (Matt. 3:13-17). (3) It was his custom to worship (Lk. 4:16). (4) He prayed (Lk. 6:12). (5) He was tempted in all points like as we are, but did not sin (Heb. 4:15). No matter what your problem is, Jesus had to face it (Heb. 4:15). A. If it is physical suffering, think of Him hanging on the tree (Matt. 27). B. If your heart bleeds with sorrow, remember Christ wept too (Jno. 11:35). C. If you have no financial security, Christ knows what that is like — he had no place to lay his head (Matt. 8:20). D. If you are caught in labor disputes, remember Jesus was once a carpenter (Mk. 6:3). E. Have friends forsaken you? Well, they forsook Jesus (Matt. 26:56). F. Are you tempted to give up the struggle of truth against error? If so, think of Christ and his stand (Matt. 23). G.. Have enemies misrepresented you? Remember: They bore false witness against Christ also (Matt. 26:60). H. Have people failed to appreciate your efforts? If so, remember Christ (Lk. 17:12-18).

“THOU SHALT BE MISSED”

I Sam. 20:18

1. *Introduction.* (1) Context: Saul was envious of David and was seeking his life. Consequently, David deemed it wise and safe to absent himself from the feast of the new moon. Jonathan said, “Thou shalt be missed, because thy seat will be empty.” (2) One who has served well is always missed when his seat is empty, whether it be caused by death or some other reason.

2. “Thou shalt be missed, *because thy seat will be empty*” (I Sam. 20:18). (1) The occupied chair in the family circle makes for joy; the empty seat makes for sorrow. (2) Some attend church so faithfully they are missed when their pew is empty. Others attend so seldom they are not missed when their seat is empty. Some die and are not missed. How terrible! (3) Occupying

a seat at church is more important than many people think. It takes the combination of the man in the pulpit and the person in the pew to carry on the services. A. The early Christians assembled on the first day of the week (Acts 20:7; I Cor. 16:2). B. We are commanded: "Not forsaking the assembling of ourselves together" (Heb. 10:25). C. Jerusalem church continued steadfastly in public worship (Acts 2:42). D. Occupying a seat at church proves one's love (Jno. 14:15, shows one's faith (Jas. 2:18), affords an opportunity to meet the Lord (Matt. 18:20), and encourages spiritual growth (II Pet. 2:2). E. If we do not enjoy this on earth, how could we enjoy heaven? F. In the fight between right and wrong, truth and error, it shows whose side we are on (Matt. 12:30). When the Yankees marched into the Southland, Granny grabbed the broom and ran out to meet them. A daughter yelled, "Granny! Granny! Come back here! What do you think you can do with that broom?" With courage, Granny replied, "Well at least, I can show them whose side I'm on." G. The empty pew has an eloquent tongue. To the preacher it says "Your efforts are not appreciated; why don't you quit?" To the treasurer it shouts, "Look out for a deficit." To the visitor it whispers, "There is no interest here; I wouldn't come back." To the faithful Christian it suggests, "The other members don't attend; you might as well be absent next time." It would be easier to make progress if we could stop the voice of the empty pew. H. We should attend all services that we be not inconsistent like the "oncercs."

O Lord, I thank thee for the love that makes my
 life so bright;
 For this I praise thee Sunday morn, but not on Sunday
 night.
 I am glad to hear our singers chant my pure and
 deep delight;
 On Sunday morn I hear them sing, but not on Sunday
 night.
 I love to hear our preacher speak; his views are
 sound and right;
 They feed my soul on Sunday morn, but not on Sunday
 night.

At 11:00 A. M. I stroll to church — in Sunday garb
bedight; but,
Lord, I crave my easy chair and slippers Sunday night.
Lord, bless the church and help to fill our preacher's
soul with might,
To charge the sinful ramparts of my empty pew at
night.

—G. C. Brewer.

3. "Thou shalt be missed," *because thy tongue will be silenced.* The Lord intended for the tongue to be a blessing. Prov. 25:11; Col. 4:6; II Tim. 4:2.

4. "Thou shalt be missed," *because thy ears will be deaf.* The world is looking for the person in whom to confide, someone to hear us, someone to bear our burdens (Gal. 6:2) and to weep with us (Rom. 12:15).

5. "Thou shalt be missed," *because thy hands will be stilled.* (1) Hands are important. The Lord gave them to use (Eccl. 9:10; Eph. 4:28). (2) Hands of the worthy woman (Prov. 31:13,16,19,20,28,31). (3) Dorcas was missed because of what her hands had done (Acts 9:36-39).

6. "Thou shalt be missed," *because thy purse will be closed.* (1) Giving is a part of the Christian life (I Cor. 16:2). (2) Poor widow's gift (Mk. 12:41-44). (3) When self is given, money follows (II Cor. 8:5). (4) Some will be missed because of their giving. Others give so little that when they are gone it will never be missed.

7. "Thou shalt be missed," *because of thy optimism.* (1) Christians should be optimistic. Paul was (Phil. 4:13). (2) "Can you do it?" a brother was asked. He replied, "With God's help, our strength is multiplied many times."

8. "Thou shalt be missed," *because of thy influence.* (1) The church is a kingdom of influence (Matt. 13:33). (2) This message is on the tombstone of a girl: "It was easier to be good when she was with us."

9. *Conclusion:* Let us so live that when we are gone we shall be missed; and our good works will follow us (Rev. 14:13); and our lives will continue to speak (Heb. 11:4).

SAINTS IN WRONG PLACES

1. *Introduction.* (1) A saint is one who has been separated and set apart to the work of God, a child of God, a Christian. A saint is not a sinless person. Members of the church at Corinth were saints (I Cor. 1:2) but were not sinless. (2) Some places are good and some are bad. It is easy to be in a wrong place.

2. *Abraham*, a backsliding believer in Egypt (Gen. 12:10-20). (1) Father of the faithful and friend of God (Jas 2:23), but his faith weakened this time. (2) Faith sustains us (Psa. 27:13; Heb. 3:12). (3) We are to walk and live by faith (II Cor. 5:7; Gal. 2:20).

3. *Elijah*, a discouraged worker under the juniper tree (I Kings 19:4). (1) At times all of us become more or less discouraged. (2) We need the optimism of Paul who said, "I can" (Phil. 4:13). (3) We should want to live to serve (Phil. 1:23,24).

4. *Jonah*, a disobedient servant asleep in the ship (Jonah 2). (1) One should not be able to sleep in disobedience. A woman once told me that she could not sleep after hearing me preach. She meant it as a rebuke, but I took it as a compliment. She needed to obey the gospel. The words spoken were tugging at her heart. (2) Our relationship to God is like that of a sailor sailing under sealed orders. God issues the commands; we obey. Mk. 14:36.

5. *Lot*, a silent witness in Sodom. He appeared as one who mocked even to his sons-in-law (Gen. 19:14). He had waited too late to preach to them.

6. *David*, an idle servant on the housetop (II Sam. 11:2-27). (1) His idleness led to sin. "Idleness is the devil's workshop." (2) I Tim. 5:13; Prov. 31:27.

7. *Demas*, a lover of the world in Thessalonica (II Tim. 4:10). The love of the world overcame him. It was not compatible with spiritual things. I Jno. 2:15-17; Jas. 4:4; Matt. 6:24.

8. *Peter*, an observer warming at the devil's fire in the high priest's house (Lk. 22:55). (1) There are dan-

gerous places to warm: pool halls, dance halls, domino halls, night clubs, bars, places of amusement that suggest the indecent. (2) Four things reveal your character: where you go; your friends; what you say; how you spend your money. (3) Should go only to the places where Jesus can go.

NEGLECTED AND REJECTED OPPORTUNITIES

1. Adam and Eve had a wonderful *opportunity* in the Garden of Eden, but they threw it away (Gen. 3:1-6).

2. Those who heard Noah preach had a glorious *opportunity to be saved*, but let it slip (Gen. 6:1-8; II Pet. 1:5). (1) Man has the opportunity today to be saved (I Tim. 2:3,4), but many let it slip (II Heb. 2:3). (2) The long-suffering of God waited in the days of Noah (I Pet. 3:20), and is waiting now (II Pet. 3:9). (3) The indifference of Noah's day is to repeat itself (Matt. 24:37).

3. Lot, living in the well-watered plains of the Jordan, had a great *opportunity*; but he pitched his tent toward Sodom (Gen. 13:12). The way you pitch your tent determines where you land. He landed in Sodom. Even in Sodom he had an opportunity to save the city — ten righteous would have done it (Gen. 18:32) — but he lost his family instead (Gen. 19:26). This has happened to many for the same reason — a move into an ungodly community.

4. When Christ was born, men had the *opportunity of entertaining him*; but they had no room (Lk. 2:7). We today can have him as our guest (Rev. 3:20).

5. Many had the *opportunity to walk with Christ*; but they rejected it (Jno. 6:66). That opportunity is also ours (Matt. 28:20).

6. Judas had the *opportunity to become great in history*; but he sold it for thirty pieces of silver (Matt. 26:15).

7. *Sundry thoughts*. (1) The Greeks pictured opportunity as a woman with her hair dangling down in front,

her head shaved in the back, treading along quietly in soft shoes. Opportunity does not come making a lot of noise, and when once it passes by, it is gone; there is nothing to catch to pull it back. (2) If you look for opportunity, you will find it; Judas did (Matt. 26:16). (3) The reason some do not see opportunity when it comes is because it comes disguised as hard work. (4) Gal. 6:10. (5) A young preacher said, "The church here is so small the opportunity is not very great; I want to go to a larger place." An older preacher replied, "The opportunity is just as great as you will want to account for in the day of judgment." Matt. 25:14-30.

8. *Various opportunities.* (1) To feed and clothe Christ (Matt. 25:34-40). (2) To study Bible (II Tim. 2:15). (3) To personally teach others (Heb. 5:12). Some are unable to take advantage of such because of a lack of preparation. "Be ready" (I Pet. 3:15). (4) To train children (Eph. 6:4). Lot seemed as one that mocked to his sons-in-law (Gen. 19:14) — what a pity. (5) To make friends in the church (Prov. 18:24).

JOHN THE BAPTIST

1. *His mission* — that of a forerunner (Mal. 3:1; Lk. 1:16,17).

2. *His parents.* They were righteous (Lk. 1:6). Fortunate is such a child (Prov. 22:6).

3. *His message.* (1) Proclaimed a twofold message (Matt. 3:1,2). (2) Demanded fruits indicating repentance (Matt. 3:7,8). (3) Preached eternal punishment (Matt. 3:12). (4) Rebuked Herod for his adulterous marriage (Matt. 14:3,4; Lk. 3:18-20). (5) Uncompromising (Matt. 11:7). Chose 'to die rather than compromise (Matt. 14:1-12).

4. *John's work as related to Christ.* (1) He prepared the way for Christ (Lk. 1:16,17). (2) He "confessed, I am not the Christ" (Jno. 1:19,20). (3) He said that Jesus was preferred before him (Jno. 1:15). (4) He stated

that he was not worthy to unloose Christ's shoe-latchet (Jno. 1:26,27). (5) John said, "He must increase, but I must decrease" (Jno. 3:30). (6) Did not want to baptize Jesus (Matt. 3:13-16).

5. *Other thoughts.* (1) Some contend that inasmuch as John was "a" Baptist then when he baptized Christ that it made Christ a Baptist. John was not "a" Baptist. He was "the" Baptist and the only man ever called such by inspiration. No organization in the Bible is called by that name. He was called the baptist because he baptized — just like one Simon was a sorcerer (Acts 8:9) and another Simon was a tanner (Acts 9:43). (2) Somebody had to baptize Christ for him to fulfil all righteousnesses (Matt. 3:15). (3) The disciples were Christians (Acts 11:26; I Pet. 4:16) — not Baptists. (4) John was dead when Jesus promised to build the church (Matt. 14:10; 16:18). (5) John was never in the church or kingdom (Matt. 11:11). (6) Some who were baptized into John's baptism were rebaptized (Acts 19:1-5).

6. *Let us follow the Christ as did John's disciples* (Jno. 1:37-42). (1) Christ is our saviour (Matt. 1:21) — not John. (2) Christ died for us (I Cor. 15:3) — not John. (3) Christ was raised for us (Rom. 4:25) — not John. (4) Christ founded the church (Matt. 16:18) — not John. (5) Christ has all authority (Matt. 28:18) — not John. (6) Christ will judge us (Jno. 12:48) — not John.

AT THE OPENING GATES OF THE NEW YEAR

1. *Introduction.* (1) New experiences await us (Josh. 3:4). (2) The future is uncertain (Jas. 4:14). But God is in the future (Psa. 90:2).

2. *We are impressed with the thought of time.* (1) Time means nothing to God because he has all of it (II Pet. 3:8). (2) Time is important to man because he has so little of it. Job 14:1,2; Psa. 90:10,12; Eph. 5:16.

3. *This is the time of year when we take stock.* (1)

Should take stock of blessings (Psa. 65:11). Count your blessings. (2) Take stock of church work. What progress has been made during past year?

4. *Lay aside the weights* which have retarded our progress during past year (Heb. 12:1). (1) Lay aside all malice, guile, hypocrisies, envies, and evil speakings (I Pet. 2:1). (2) Lay aside lukewarmness (Rev. 3:15,16). (3) Lay aside worldliness (Jas. 4:4; I Jno. 2:15-17). (4) Lay aside sorrows. In the most sheltered life storms and disappointments will come, but they should be accepted so as to become wings and not weights. A piece of tallow and a piece of clay can be placed equal distances from a flame. One will be melted and the other hardened. Some experiences may harden some and melt others. (5) Lay aside everything that absorbs our energies and retards our progress (Matt. 13:45,46).

5. *Resolve*. (1) Good resolutions are necessary to moral and spiritual advancement. (2) When the water pitcher is broken at our house we do not quit drinking water. When resolutions are broken, we should not quit. (3) Resolve to make this a happy year (Psa. 144:15). (4) Resolve to improve ourselves (I Pet. 2:2) and to become more like Christ (I Pet. 2:21). A. When Thorwaldsen was asked, "Which is your greatest statue?" he replied, "The next one." B. Cromwell wrote in his Bible, "If I cease to become better, I shall cease to be good." (5) Resolve to read the Bible (I Tim. 4:13) and to pray every day (I Thess. 5:17). (6) Determine to resist the devil (Jas. 4:7,8). A farmer who became a Christian was having to fight stinginess. He was asked to assist a needy family and went to the smokehouse to get a piece of meat. As he opened the door, the tempter whispered, "Give him the smallest piece." But the farmer turned and said, "If you don't shut your mouth I will give him every piece in here." (7) Resolve to keep the peace — so many churches are having strife. Rom. 14:19; Matt. 5:9; Prov. 20:3; Psa. 133:1. (8) Purpose to go forward (Phil. 3:13,14; Lk. 9:62).

ARE WE GOING TO TAKE THE BACKBONE OUT OF THE CHURCH OF CHRIST?

1. *Introduction.* (1) Backbone defined: the spine; firmness; moral courage. (2) There are certain straws in the wind that should cause alarm.

2. *Present trends.* This is not true of the whole church, but is true of many. (1) Sin is winked at; worldliness is not rebuked; lukewarmness is prevalent. (2) Pride is prominent because of our growth; love of popularity is strong. (3) Sunday morning Christians are becoming the fad of the day; gospel meetings are only weak gestures; lots of church work but little soul-winning; lots of activity but little spirituality — a woman said, "I'm so busy doing church work I don't have time to save the lost." (4) Efforts are being made to change our style of preaching, remodel the gospel, and modernize the church.

3. *What has brought on these dangerous tendencies?* (1) Maybe, success. It is easy to outgrow our plea. (2) Maybe, less opposition. We once had to fight hard, and hardships strengthened us. Now it is much easier. (3) Little indoctrination; consequently, the church is being filled with people who know not the Restoration Movement. I Tim. 4:16; II Jno. 9-11. (4) Influence of religious neighbors. Their compromising attitudes toward doctrine and morality may have rubbed off on us. (5) Swinging to extremes. Once we were hard and undiplomatic; now we have become soft and apologetic. Once we had mostly doctrinal preaching; now doctrine is seldom mentioned. Once we had nearly all negative preaching; now we have largely positive preaching. Once the services were disorderly; now they are becoming cold and icy with ritualism. Once our preachers did only a little personal work; now their personal work is so heavy that they have little time for study and prayer — the trend is to make them glorified red caps and jumping bell hops. Extremes are dangerous.

4. *Scriptures on firmness.* Jude 3; Phil. 1:17; Eph.

4:14; 6:17; Tit. 1:13; I Tim. 6:20; II Tim. 2:13; 4:3,4; Gal. 1:8,9; Rev. 22:18,19; II Jno. 9-11.

5. *Truth is fixed, unalterable, and unchangeable.* The truth in these passages is everlasting and cannot be altered to fit a changing world: Eph. 4:4-6; Matt. 15:9,13,14; Rev. 22:18,19; Jas. 4:4; I Heb. 10:25; Rev. 20:12.

6. *Quite a few efforts are being made to modernize our preaching and humanize the church;* for instance we hear: "Don't preach a negative gospel." But God did — eight of ten commandments are negative (Ex. 20)! Paul told Timothy to reprove and rebuke (II Tim. 4:2) — negative. We cannot stand for something without standing against something (Psa. 97:10). (2) "Preach the Bible and let everybody else alone." If this were followed, we could not preach Gen. 1:1 — disturbs atheist; nor Ex. 20:3 — upsets heathen; nor Heb. 11:6 — condemns moralist; and on and on. (3) We are told that firmness is not the spirit of Christ, but read Matt. 23.

7. *Should learn from the past.* (1) Apostasy soon came as prophesied (I Tim. 4:1-3; II Thess. 2:3,4). (2) During the past century digression developed because the motto, "Speak where the Bible speaks; be silent where the Bible is silent" became a forgotten slogan. Remember this principle of life: What has happened can happen! Apostasy has happened; it can happen again.

FREEDOM FROM YOUR SELF-PRISONS

Lk. 4:16-18

1. *Introduction.* (1) All the people in prison are not behind stone walls. "Stone walls do not a prison make, nor iron bars a cage." (2) There is a stronger and more unyielding prison bar than one made of iron. It is a thought or attitude of life. Charles Dickens expressed it, "I wear the chain I forged in life." Indeed we forge our own chains which enslave us. (3) If you have been imprisoned by anything — your lusts, your hates, your temp-

tations, your resentment, your grudges, your sins — let Jesus Christ make you free.

2. *A prison of self-satisfaction.* (1) Many people do not want to be any different — self-satisfied. (2) You cannot overcome a weakness by giving in to it. If one has the problem of stage fright he may overcome it by going before the people. If one has a lazy, easy-life complex, he may overcome it by working and assuming responsibilities. (3) We should make improvements and grow (I Pet. 2:2; Heb. 12:1,2; Phil. 3:13,14).

3. *A prison of inferiority.* (1) This is a feeling of defeat. Many have to fight a feeling of inability. (2) Strength to overcome is found in Matt. 28:20 and in Phil. 4:13.

4. *A prison of superstition.* (1) Over \$125,000,000 are spent every year in America on various forms of superstition. A survey shows that practically one-half of the people in America believe in some kind of fortune-telling. When their hearts fail them, they go to some tea-leaf reader or crystal-gazer instead of the house of God. (2) Famous superstitions: Friday the thirteenth, black cat, break mirror, walk under ladder, eat black-eyed peas on January 1st. (3) There is much superstition in religion. But Christianity is a religion of truth and knowledge — not superstition (Jno. 8:32).

5. *A prison of hate.* (1) Many lives are filled with bitterness and hatred. It has warped personality. (2) Jesus knew best when he taught us to love instead of hate. (Matt. 5:43,44).

6. *A prison of unrest.* (1) This explains the superficial search of amusement and pleasure on the part of many — unrest. (2) It is the key to many suicides. (3) Gambling is not only a manifestation of materialism, but also of unrest. (4) Many are trying to free their anxieties in alcoholic beverages but instead have enslaved themselves (Tit. 2:3). (5) Others are seeking peace in cheap literature (Phil. 4:8). (6) The world is restless. Confusion is everywhere — in business and labor, in politics, in gov-

ernment, and in religion. (7) The answer to all these problems is found in the statement, "To live is Christ" (Phil. 1:21). We shall have to get back to the Lord we have forsaken before we get any rest (Matt. 11:28-30). Then we can have "the peace of God, which passeth all understanding" (Phil. 4:7).

7. *A prison of indecision.* (1) Man must everlastingly make decisions. It is a part of life. (2) How do we get the wisdom for right decisions? Jesus is our example (1 Pet. 2:21).

8. *A prison of unbelief.* (1) Doubts torment multitudes. They just do not believe. (2) Faith released Paul from prison (II Tim. 1:12).

9. *A prison of sin.* (1) Isa. 59:2. (2) God has a law of pardon for the alien sinner and also another law of pardon for the erring Christian. Obedience to God's law will release us.

"I AM A DEBTOR"

Rom. 1:14,15

1. *Introduction.* (1) Paul was in debt — not at the bank or the department store. (2) We, too, owe a monstrous obligation.

2. *To God.* (1) He made the world (Gen. 1:1; Acts 17:24). (2) Created man (Gen. 1:27; 2:7). Made him flesh and spirit (II Cor. 4:16; Eccl. 12:7). Gave him dominion over every other creature (Gen. 1:26). Blesses us (Jas. 1:17). (3) Man is to pay this debt by glorifying God (Eccl. 12:13; Matt. 5:16).

3. *To parents.* (1) Cared for us; sacrificed for us. (2) How can we repay them? A. Reflect honor upon them in our lives (II Tim. 1:5). B. Provide for their material assistance if they need it. Jesus did (Jno. 19:27). C. Rear children of our own. This perpetuates the race (Gen. 1:28). D. Thank them. Let us not take their sacrifices and services for granted on the basis that they owed us such. As parents become older, expressions of gratitude

mean more to them. A grateful child is a source of delight.

4. *To Christ.* (1) Died for us (I Pet. 2:24). (2) Left us an example (I Pet. 2:21). (3) We should attempt to repay this by following him and by preaching to others (Matt. 16:24; Rom. 1:14-16).

5. *To early Christians.* (1) Died rather than deny the faith. If they had been popularity-seeking, spineless time-servers, the story of Christianity would have been different. (2) We are to repay them by keeping alive the cause for which they died.

6. *To Johannes Gutenberg.* (1) He invented the printing press. Previously the cost of a Bible was prohibitive. (2) Repay him by reading the Word and by keeping the presses busy for Christ.

7. *To our free schools.* (1) Ignorance makes for bondage. Knowledge makes for freedom, politically and spiritually. (2) Support them. Keep church and state separate. Jesus separated them in his teaching (Matt. 22:21).

8. *To the restorers.* (1) They broke the shackles of Romanism and Protestantism. Restored the Christianity of the first century. (2) Repay them by handing it down to others in purity (II Tim. 2:2; 4:3,4).

SPIRITUAL AILMENTS

I Cor. 11:30

1. *Hypochondria* — morbid anxiety as to one's own health, with conjuring up of imaginary ailments. (1) For instance, some people imagine they have been mistreated; they take their exercise jumping at conclusions. (2) Some imagine they cannot do things for the Lord. Their defeat is due to their mental outlook. They are like the spies (Num. 13:31,33) and the one-talent man (Matt. 25:25).

2. *Carditis* — inflammation of the muscular substance of the heart, heart trouble. (1) Evil conduct is due to an evil heart (Matt. 15:19). Prov. 4:23. (2) The word of God pricks the heart of the spiritual man (Acts 2:37).

3. *Elephantiasis* — the skin becomes thick and hard

like an elephant's skin. (1) People afflicted with the disease have thick skins; are hard to reach. (2) Should be compassionate and tender hearted (I Pet. 3:8; Col. 3:12; Rom. 12:15).

4. *Myopia* — nearsightedness, seeing distinctly at short distances only. (1) Spiritually, farsighted vision is essential to survival (Prov. 29:18). (2) He who fails to add the Christian virtues has spiritual myopia (II Pet. 1:5-9).

5. *Hyperopia* — farsighted, sees objects better at a distance. (1) Some people can see big and distant things in the Lord's work, but cannot see the little things close by. (2) They are good at spreading a feast, but no good at giving a cup of cold water (Matt. 10:42). (3) They are good at trying to convert people in mass form, but no good at preaching to a lone hearer (Lk. 16:10).

6. *Rachitis* — a disease in which the head enlarges and the bones become mishapen, rickets. (1) Spiritually — the big head, egotistical. (2) Matt. 18:4; Col. 3:12; I Pet. 5:5; Prov. 6:16,17; 16:18.

7. *Chills* — a sensation of cold, attended with shivering. Spiritually, this is brought on by sin (Matt. 24:12).

8. *Fever* — patient runs an abnormal amount of temperature. (1) Spiritually, a hot temper. (2) Jas. 1:19; Eph. 4:26.

9. *Encephalitis lethargica* — sleeping sickness. (1) Many church members are afflicted with this ailment. (2) I Thess. 5:6; Eph. 5:14.

10. *Atrophy* — wasting away of any part of the body; lack of growth from want of nourishment; may have atrophy of muscle, eye, arm, or leg. (1) Spiritually, many church members have it one way or another. (2) Christians should grow and develop (I Pet. 2:1,2).

11. *Scurvy* — patient becomes very weak and thin. (1) "For this cause many are weak and sickly among you, and many sleep" (I Cor. 11:30). (2) Church at Sardis also had spiritual scurvy (Rev. 3:2).

12. *Hydrophobia* — a symptom is the fear of water;

getting close to water brings on convulsions. (1) Pharisees and lawyers had it (Lk. 7:30). (2) Jesus was not bothered with it (Matt. 3:13-17). (3) Those afflicted with it cannot enjoy remission of sins (Acts 2:38) or enter Christ (Rom. 6:3,4).

13. *Itch* — patient has an uneasy sensation which inclines him to scratch. Spiritually, it causes the afflicted to seek teachers who will tickle their ears (11 Tim. 4:3,4). This ailment is more common than many people think.

14. *Sunday moribis* — Sunday sickness. (1) This disease is peculiar in that it strikes only on Sunday. Saturday, patient feels good and has a vigorous day; Sunday, he feels terrible and is unable to go to church, but shows marked improvement by noon; Monday morning, he feels good and is able to go to work. (2) The only cure is for the patient to become converted so that he will obey Acts 20:7 and Heb. 10:25.

THE PROOF OF TIMOTHY

Phil. 2:22

1. *Introduction.* (1) One may prove his religion. A. By giving chapter and verse (Acts 17:11; II Tim. 3:16,17). B. By being transformed (Rom. 12:2). (2) Note the proof of Timothy.

2. He was a disciple or learner (Acts 16:1) — *this proved his interest in divine things.* (1) II Tim. 3:15. (2) Only those who are interested will study and learn.

3. He was unselfish (Phil. 2:20,21) — *this proved his love.* (1) Love is unselfish (I Cor. 13:5). (2) This is a God-like and Christ-like trait (Rom. 5:8; Jno. 10:11,18).

4. He served (Phil. 2:22) — *this proved his greatness.* (1) Service proves true greatness (Matt. 23:11). (2) Christianity is a religion of service (Matt. 20:28). (3) The world is interested in service. This is evident from the prominence of the word on men's backs, etc.

5. He was a worker (Rom. 16:21) — *this proved his faith* (Jas. 2:18).

6. He was a workfellow (Rom. 16:21) — *this proved his peacefulness*. (1) We must work together (II Cor. 6:1). (2) Some people have to work over you or against you; they cannot work with you (III Jno. 9:10).

7. He became "all things to all men" that he might save some — *this proved his soul-winning spirit*. This is evident from his being circumcised even though it had no religious significance at that time (Acts 16:3).

8. He held the faith when others shipwrecked it (I Tim. 1:19,20) — *this proved his doctrinal soundness*. (1) Doctrinal unsoundness shows a disrespect for God's word (Rev. 22:18,19; Gal. 1:8,9). (2) I Tim. 4:16.

"IT IS BETTER"

1. "*It is better to trust in the Lord than to put confidence in man*" (Psa. 118:8). (1) Everyone who has dealt with the public knows this is right. Man may deceive, lie, and cheat; he may be motivated by selfishness, covetousness, spite, and a love for popularity; he is sinful (I Jno. 1:8). (2) "Let God be true, but every man a liar" (Rom. 3:4). Prov. 3:5.

2. "*It is better to hear the rebuke of the wise, than for a man to hear the song of fools, For as the crackling of thorns under a pot, so is the laughter of the fool*" (Eccl. 7:5,6). (2) By observing what causes men to laugh, you are given an insight to their character. (2) Fools cannot help us; but the wise can, even though it is a rebuke. (3) We prefer compliments, but oftentimes rebuke is more needful. II Tim. 4:2.

3. "Wherefore if thy hand or thy foot offend thee, cut them off, and cast them from thee: *it is better for thee to enter into life halt or maimed, rather than having two hands or two feet to be cast into everlasting fire*" (Matt. 18:8,9). (1) Man just cannot have everything; therefore, he must decide which is better. Things eternal are better than the temporal (Mk. 8:36,37). (2) Should give up whatever is necessary to gain Christ (Phil. 3:7,8). (3) Self-

denial is a prerequisite to following Christ (Matt. 16:24). (4) We should put first things first (Matt. 6:33). (5) The parable of the Pearl of Great Price is a lesson on values (Matt. 13:45,46).

4. *"Better is it that thou shouldest not vow, than that thou shouldest vow and not pay"* (Eccl. 5:5). A vow is a solemn promise, one especially made to God. (1) "When thou vowest a vow unto God, defer not to pay it; for he hath no pleasure in fools: pay that which thou hast vowed" (Eccl. 5:4). Did you make a vow in times of crisis, sickness, or death? Jonah did (Jonah 2:9). Jacob made a vow on giving (Gen. 28:22). What about your vow on giving? (2) Covenant-breakers are condemned (Rom. 1:31).

5. *"For wisdom is better than rubies; and all the things that may be desired are not to be compared to it"* (Eccl. 8:11). (1) Wisdom is defined: "quality of being wise; ability to judge soundly and deal sagaciously with facts; discernment." You can educate a parrot, but you cannot give him wisdom. (2) "Wisdom is better than strength" (Eccl. 9:16). (3) "Wisdom is better than weapons of war" (Eccl. 9:18).

6. *"It is better to dwell in the wilderness than with a contentious and an angry woman"* (Prov. 21:19). Prov. 21:9. The same principle of life is also true of a man. (1) Peace is more valuable than a castle. The Lord teaches peace (Rom. 14:19; 12:18). (2) Woman is the keeper at home, and should keep a pleasant home (Tit. 2:5). "It takes a heap o'livin' in a house t' make it home." Edgar A. Guest.

7. *"Better is a dinner of herbs where love is, than a stalled ox and hatred therewith"* (Prov. 15:17). (1) It is better to enjoy less where there is true hospitality than to have much where it is given reluctantly. "The gift without the giver is bare." (2) The story goes that a poor widow invited the preacher to eat in her home. She served him only bread and water and said, "If you are a

Christian, this is good enough for you; if not, it is too good for you."

8. "*For it is better, if the will of God be so, that ye suffer for well doing, than for evil doing*" (I Pet. 3:17).

(1) We are going to be criticized whether we do right or wrong. So be sure you are right and go ahead. (2) Jesus was criticized for eating with sinners (Matt. 9:11), because of his family and poverty (Matt. 13:55), because of the community in which he lived (Jno. 1:46), and for healing on the Sabbath (Jno. 5:1-16).

9. "*A good name is better than precious ointment*" (Eccl. 7:1). (1) It is man's greatest material asset. It is more valuable than great riches (Prov. 22:1). Yes, there is something in a name. (2) A man's name and influence will live after he has died (Rev. 14:13).

KINDS OF FOLLOWERS OF CHRIST

1. *The afar-off* (Matt. 26:58). (1) At one time this is the way Peter followed. He did not wish to follow Christ closely; neither did he wish not to follow at all. True of many. (2) This afar-off following led Peter to deny Christ (Matt. 26:69-75). (3) The safe way to live is to resist the devil and draw nigh to God (Jas. 4:7,8).

2. *The bread-seekers* (Jno. 6:26). (1) Their feigned hunger for the bread of life (Jno. 6:35) was to secure the bread that perisheth. Their interest was strictly material; their motives were wholly ulterior. (2) A lady once said, "Well, I thought when we became members of the church of Christ they would help us." They were bread-seekers. (3) The Christian spirit is that of giving rather than getting, serving rather than being served (Matt. 20:28; Eph. 4:28).

3. *The glory-seekers* (III Jno. 9). (1) Diotrephes belonged to this classification. He was willing to work in the church if he could have the preeminence. True of many. They have a "big shot" complex; they are selfish and self-centered; they think the whole world revolves

around them. (2) Most of the petty and many of the major problems in church work have this as the basis. The trouble-makers feel that they are not getting enough honor and attention. They have such a high regard for self that it is easy for their greatness to be offended. (3) They need to learn humility (Matt. 18:3; 23:11).

4. *The critical* (Jno. 12:3-8). (1) Judas criticized Mary's anointing Jesus. It caused a murmuring among the disciples (Mk. 14:4,5). No matter how unfounded an adverse criticism may be, there are always others who will join in and echo it. "One sinner destroyeth much good" (Prov. 9:18). (2) Judas said that he was opposed to the anointing because he wanted to give the price of the ointment to the poor — he lied; he cared not for the poor; he was a thief (Jno. 12:4-6). A man's real reason for criticizing a thing may be very different from what he says; the chances are he will not state the real reason. The critic is often guided by impure motives.

5. *The fussy* (Phil. 4:2). (1) The relationship between Euodias and Syntche was so bad that it called for public mention. Two people cannot walk with the third person without all three walking together. So when two people are not walking together, then at least one of them is not walking with Christ. (2) War — both carnal and spiritual — is costly (Gal. 5:15). Peace in the church is not a luxury; it is a necessity (Matt. 5:8; Rom. 14:19; 12:18).

6. *The fearful* (Mk. 4:36-41). (1) Jesus said to this tempest-tossed, scared group, "Why are ye fearful? O ye of little faith?" (Matt. 8:26). So fear is the product of a little faith. (2) Where there is a strong faith there is no fear of starving (Matt. 6:25-33), no fear of man (Heb. 13:6), no fear of persecution (Matt. 10:28), and no fear of death (Psa. 23:4).

7. *The sacrificial* (II Cor. 8:1-5). (1) Here is one example of some people's giving more than they were able, but this is very unusual. (2) The Christian life is a life of sacrifice (Rom. 12:1).

8. *The faithful-unto-death* (II Tim. 4:6-8). (1) Paul is an example; he entered the fight to triumph; he entered the race to win; he embraced the faith to keep it. (2) Perseverance is essential to eternal salvation (Matt. 10:22; Rev. 2:10).

YOU ARE THE ANSWER TO THE QUESTION

1. *Introduction.* Man is a free moral being and thus is the answer to many questions (Josh. 24:15).

2. *Have you been saved?* (1) God, Christ, and the Holy Spirit are anxious to save (I Tim. 2:3,4; Matt. 23:37; Rev. 22:17). (2) Others can do much for you — preach to you and pray for you — but cannot decide for you. (3) As Felix and Agrippa decided (Acts 24:24; 26:28) so must you.

3. *Is your life going to be happy?* (1) Happiness cannot be bought, begged, borrowed, or stolen. But it is within the grasp of each. (2) The Lord wants you to be happy (Matt. 5:12). (3) The word “blessed” with which each of the beatitudes begins comes from the Latin word, “*beati*,” which literally means “happy.” So Jesus tells us in the beatitudes how to be happy. (4) Happiness comes from obedience to the Lord and a close relationship with him (Psa. 144:15; Acts 8:39). (5) Happiness does not depend upon material things (Lk. 12:15; Phil. 4:11).

4. *Are you going to have friends?* To have friends you must: A. Be a friend. B. Be friendly (Prov. 18:24). C. Be unselfish (Phil. 2:4). D. Do things for others (Matt. 23:11).

5. *Will the church continue to grow?* (1) The church grew in the first century (Acts 2:47; Acts 4:4) (2) It grew because of what the members did (Acts 2:42; Col. 1:23). They were the church. (3) If a congregation does not grow, it is its own fault.

6. *Is the church going to be strong?* (1) In friendliness? Matt. 25:35. Robert Burns, the national poet of Scotland, was in a strange city and was feeling very lonely.

He went to church, but received no word of welcome and no hand of friendship. But before he left he scribbled this bit of verse on the flyleaf of the song book:

As cauld a wind as ever blew;
 A caulder kirk, and in't but few;
 As cauld a minister's e'er spak;
 Ye'll all be hot ere I come back!

The person sitting next to you may be a good friend you just haven't met. (2) In soul-winning? Prov. 11:30; Jas. 5:19,20. (3) In sacrifice? Rom. 12:1. (4) In knowledge? Hos. 4:6; I Tim. 4:13. (5) In attendance? Heb. 10:25.

7. *Is the church going to remain sound in the faith?* (1) II Tim. 1:13; Tit. 1:13. (2) Unsoundness is a gradual process. It begins with an attitude and comes slowly, step by step (II Tim. 4:3,4).

8. *Are you going to heaven?* (1) All are going some place (Matt. 25:31-46; Rev. 20:12). (2) The Lord has gone to prepare it (Jno. 14:1-4). Are you prepared for it?

JUDAS ISCARIOT

1. Judas' betrayal of Jesus *fulfilled prophecy*: "Yea, mine own familiar friend, in whom I trusted, which did eat my bread, hath lifted up his heel against me" (Psa. 41:9). The Lord did not make Judas do it, but could foresee that he would.

2. One of the forceful lessons we learn from Judas is that *there is something in a name*. (1) We name our sons James, John, Peter, and Paul — not Judas. We name our daughters Ruth, Mary, Martha, Elizabeth — not Jezebel. (2) There is so much in a name that God changed Abram's name to Abraham and Sarai's name to Sarah (Gen. 17:5,15). (3) It is important that children of God wear the name "Christian" rather than human names (Acts 11:26; I Pet. 4:16; Acts 4:12).

3. Another lesson we learn from Judas is that *a disciple of Christ can fall*: "Judas by transgression fell,

that he might go to his own place" (Acts 1:25). (1) "And one of you is a devil" (Jno. 6:70) — it does not say that Judas was a devil from the beginning, as some think. If so, from what did Judas fall? (2) Satan entered into him. "Then entered Satan into Judas" (Lk. 22:3). (3) Disciples today need to take heed lest they fall and lose their souls (I Cor. 10:12; Heb. 3:12; Matt. 13:41,42; Jno. 15:6).

4. We also learn from Judas *the vice of wrong motives*. (1) He said the ointment could have been sold for 300 pence and given to the poor; but his concern for the poor was not the real motive (Jno. 12:3-8). He fomented discontent among the disciples over Mary's anointing Jesus, and they murmured (Mk. 14:5,6). One person with a wrong motive can create much dissatisfaction and backbiting. (2) Judas kissed Jesus, but the motive was to betray him (Matt. 26:47-49). That which could have been the whitest was the blackest because of motives. (3) Jesus taught some great lessons on motives (Matt. 6:1-18).

5. *Judas had the same opportunities as the other apostles*. (1) The difference in them is that he squandered his opportunities. (2) He allowed his heart to become evil. The condition of the heart affects the life and the production of gospel fruit (Prov. 4:23; Matt. 13:3-8,19-23).

6. When Judas saw the results of his betrayal, *he repented and hanged himself* (Matt. 27:3). (1) Two different Greek words are translated "repented." The one used here is "metamellomai," used only five times, which literally means "to care after," indicating a sorrow for the past, regret. The other Greek word is "metanoeo," which literally means "to know after," indicating a change of mind or purpose, repentance in the ordinary gospel sense. (2) Judas was possessed with an after-care, regret, not sorrow for sin against God, but annoyance at the consequences of an act. In view of the prophecy which had been uttered in regard to Judas' sin, he had good reason to fear the consequences (Matt. 26:24). Judas surely regretted his act. If things could be done twice, all of us would be wiser.

(3) Judas proved his repentance to be different from gospel repentance by committing another sin, suicide.

7. *Judas' confession*: "I have sinned in that I have betrayed the innocent blood" (Matt. 27:4). (1) If Jesus had been a deceiver, Judas would have known it and would have revealed it. (2) But the very man who betrayed Christ — under no compelling power except that of his own conscience — admitted Christ's innocence. This is a great argument for the truthfulness of Christianity.

8. *Judas went "to his own place"* (Acts 1:25). (1) To the place of betrayers and other sinners. (2) Two men died, and each went to his place (Lk. 16:19-24). (3) Heaven was not the place for Judas, because he had not prepared himself for it.

9. "*It had been good for that man, if he had not been born*" (Matt. 26:24). "Woe unto that man by whom the Son of man is betrayed" (Matt. 26:24). This is true of all who betray Jesus. Let us take heed and beware!

WHAT DOES IT MEAN TO RECEIVE THE WORD?

Acts 2:41

1. *Those who received the Word on Pentecost* (Acts 2:36-41). (1) They believed, repented, and were baptized. The meaning of each. (2) God did the adding to the church (Acts 2:47).

2. *In receiving the Word man saves himself*. (1) This is evident from Peter's exhortation (Acts 2:40,41). (2) In rejecting the Word man condemns himself (Acts 13:46). (3) Jas. 1:21. (4) The wayside hearer in the parable of the sower did not receive the Word (Matt. 13:3-9,18-23).

3. *It means to receive all of it*. (1) Jas. 2:10. (2) Must have a spirit different from that in Isa. 30:9,10.

4. *Receiving the Word necessitates man's giving up error*. (1) For the Word is truth (Jno. 17:17). (2) Paul did (Phil. 3:4-7).

5. *Some people who think they want to receive the*

Word actually do not. The cost is more than they are willing to pay (Matt. 19:16-22).

6. For man to be eternally saved he must do more than receive the Word — he *must allow it to abide in his heart.* (1) Matt. 13:20-23. (2) Those who received the Word on Pentecost continued steadfastly (Acts 2:42). Steadfastness is very important (I Cor. 15:58).

SELF

1. *Self-complacent* — satisfied or pleased, self-contented. (1) This describes the churches at Sardis (Rev. 3:1,2) and Laodicea (Rev. 3:14-17). **True of many today.** (2) Self-complacency is antipodal to the spirit of Christianity (Phil. 2:12; 3:13,14).

2. *Self-conceited* — an exaggerated estimate of one's own abilities or powers. (1) Two preachers were discussing the capability of another preacher. One said, "How good is he? Is he as good as you are?" The other replied, "No. He is about like you are." (2) If we could buy some people for what they are worth and sell them for what they think they are worth, we could make a fortune in one trade. (3) God hates pride (Prov. 6:16). (4) It is of the world (I Jno. 2:15-17). (4) God resists the conceited (Jas. 4:6); they shall be abased (Lk. 14:11).

3. *Self-indulgent* — giving free course to one's own passions, desires, inclinations. (1) The sin of Demas (II Tim. 4:10). (2) This person does as he pleases — does not pray, "Thy will be done" (Matt. 6:10). (3) Should fight this sin with self-denial (Matt. 16:24).

4. *Self-righteous* — righteous in one's own eyes. (1) This was the sin of the praying Pharisee (Lk. 18:9-14). (2) The self-righteousness of the Pharisee prompted them to accuse Jesus for eating with sinners (Matt. 9:10-12).

5. *Self-willed* — obstinate, stubborn, set on having one's own will. (1) A bishop must not be self-willed (Tit. 1:7). (2) II Pet. 2:10. (3) The sin of Jonah (Jonah 1). (3) Two goats met on a narrow bridge. Neither would

give way to the other. They rammed each other; both fell off; and both perished.

6. *Self-centered* — absorbed in self. (1) Some are so self-centered that they cannot appreciate a funeral sermon because they are not the corpse about whom the nice things are said. (2) A child jerked a scarf off a table and the lamp was broken. Why did he do it? He was not getting enough attention. Some adults in the church behave in a similar way. They crave attention. (3) Priest and Levite were too self-centered to help the needy man (Lk. 10:30-37). (4) Self-centered people are always unhappy. Someone asked Socrates why Alcibiades, a man who had traveled and seen much of the world, was still an unhappy man. The great sage replied, "Because wherever he goes, he always takes himself with him." Happiness comes from thinking of others. So for our good, as well as the good of others, we must not be self-centered (Phil. 2:4).

7. *Self-denying* — denial of oneself; this is a Christian trait. (1) Self-denial is a prerequisite to following Christ (Matt. 16:24). (2) We should give up everything that interferes with a pure and unspotted life (Jas. 1:27). (3) It is far better to give up the temporal things of life than to lose one's soul in torment (Matt. 18:8,9).

8. *Self-controlled* — control of oneself; this is another Christian characteristic. (1) "He that ruleth his spirit [is greater] than he that taketh a city" (Prov. 16:32). This was written at a time when to take a city was the greatest of human accomplishments. But at that distant age men were taught that a greater achievement was the conquest of self. (2) One of the graces we are to add to the faith is temperance or self-control (II Pet. 1:5,6). (3) A horse or an engine out of control is a dangerous thing; but the most dangerous of all is a man out of control. Peter the Great was the maker of modern Russia. But he was subject to outbursts of madness, and in one he killed his own son. Toward the end of his reign he said, "I have conquered an empire, but I was not able to con-

quer myself." He who is unable to control self is not prepared to control others.

9. *Self-sacrificial* — sacrifice of oneself, another Christian trait. (1) The Christian religion is one of sacrifice. God gave; Jesus gave; and we are to give. (2) The greatest gift is self. When self is given, all other gifts come easily (II Cor. 8:5).

PUTTING AWAY CHILDISH THINGS

I Cor. 13:11

1. *Introduction.* A man behaves differently from a child.

2. *There are some traits of childhood we should never put away* (Matt. 18:3,4). (1) Innocence. Matt. 18:3 and Gen. 8:21. (2) Simple faith and trust. Example: A team hitched to a wagon ran away. Child later said, "I wasn't afraid because my daddy was with me." Man needs such faith. Isa. 12:2; Heb. 11:24-26. (3) Sympathy. Seen in their attitude toward a crippled bird or a mangy dog. Rom. 12:15; Eph. 4:32. (4) Easily entreated. Tit. 1:7; II Pet. 2:10. (5) Forgiving. Can fuss and fight and be back playing together in thirty minutes. Col. 3:13.

3. *There are some childish things we should put away.* (1) Gossip. They tattle. Lev. 19:16; I Tim. 5:13. (2) Desire attention. If they cannot get attention by being good, they will be bad. True of some adults. I Pet. 5:6. (3) Envy and jealousy. May step on another's new shoes, etc. Adults are envious of another's success, business, clothes, etc. Prov. 14:30; Matt. 27:18. (4) Crave amusement. Many people can find no entertainment in study, self-improvement, or in help to others, but only in that which is outside themselves. A pleasure-loving world. II Tim. 3:4; Jas. 5:5. (5) Want to play all the time. II Thess. 3:10; Phil. 2:12. (6) Unsteadfast. Hard to keep them at work; will not finish a job. I Cor. 15:58; I Cor. 16:13. (7) **Fussy.** Will argue about anything. Husband said to wife, "Let's not fuss tonight. I feel so bad. Let's wait until I get to

feeling better so I can enjoy it." Matt. 5:8; Rom. 14:19. (8) Discourteous. Children can be cruel. The things they say to each other: "Johnny is a sissy"; "Mary's hair looks like a horse's tail." I Pet. 3:8. (9) Pout. Enjoy feeling that they have been mistreated. I Cor. 13:11.

THE BIBLE IS A BOOK ON GIVING

1. *The Bible itself is a gift* (II Tim. 3:16,17).
2. *The creation.* (1) God gave us this world (Gen. 1). (2) God gave man life (Gen. 1:27; 2:7). (3) God gave man dominion over every other creature (Gen. 1:26). (4) Nothing really belongs to man; it is all given him for his use (I Tim. 6:7,8). How much interest should we pay for the use of God's things?
 3. *God gave man a home in the garden* (Gen. 3).
 4. *When man fell, God gave him promise of a redeemer* (Gen. 3:15).
 5. *One of the first things man ever did was to sacrifice to God* (Gen. 4).
 6. *When the world was so wicked, God gave a plan whereby man could escape destruction* (Gen. 6:5-22).
 7. *The first thing Noah did after leaving the ark was to sacrifice* (Gen. 8:20).
 8. *After the flood, God gave man the promise that he would never again destroy the world with water* (Gen. 9:13).
9. *Under the Patriarchal law, man gave the tenth.* (1) Abraham gave a tenth to Melchizedek (Gen. 14:17-20). (2) Jacob promised the Lord a tenth (Gen. 28:22).
10. *God gave the law of Moses.* (1) It was a schoolmaster given in preparation for another gift, Christ (Gal. 3:24). (2) It was to last until Christ came (Gal. 3:19,16). (3) Under this religion, God commanded the Jews to give the tithe (Lev. 27:30-32; Mal. 3:8,9). (3) The Old Testament begins and ends with giving.
11. *The gospels center around the topic of giving.* (1) God gave his Son to the world (Matt. 1:21; Jno. 3:16).

(2) The Son taught the world: "It is more blessed to give than to receive" (Acts 20:35); that they would have to give the whole heart (Matt. 23:37); that they would have to give self (Matt. 16:24). (3) Many gave much: the apostles, poor widow (Mk. 12:41-44). (4) Jesus gave his life for us (Jno. 10:18; Matt. 26:28). (5) Joseph gave his own new tomb in which Jesus could be buried (Matt. 27:60). (6) The two Marys gave of their sleep and time on the first day of the week to go to His tomb to be near His body (Matt. 28:1).

12. *Acts of the Apostles is a book on the acts of giving.*

(1) Christ gave the Holy Spirit as he had promised (Acts 1:4,5; 2). (2) The members of the Jerusalem church gave of their possessions and goods (Acts 2:45). (3) Early church gave to widows (Acts 6). (4) Stephen gave his life (Acts 7). (5) Every act of the apostles was an act of giving.

13. *All the letters to individuals and churches were written telling them how to give their lives to the Lord in acceptable living.* Some letters definitely specified giving: Rom. 12:1; I Cor. 16:2; II Cor. 8:1-7; 9:7.

14. *Revelation closes with the idea of God's giving man a new home, heaven (Rev. 21).* So the New Testament begins and ends with giving.

THE PRAYER OF EXAMPLE

Matt. 6:9-13

1. *Introduction.* Many call this the Lord's prayer, but it is actually a prayer of example rather than one the Lord prayed. Let us study it part by part.

2. *"Our Father which art in heaven."* (1) This recognizes the fatherhood of God. He is Father by right of creation (Gen. 1:1), by right of preservation (Matt. 6:25-30), and by right of redemption (Jno. 3:16,17). (2) This phrase also recognizes heaven (II Cor. 5:1; Jno. 14:1-4). (3) Jesus said to sinners, "Ye are of your father the devil" (Jno. 8:44). So how can sinners spiritually

have God as their Father? They cannot unless they are born again (Jno. 3:3-5).

3. "*Hallowed be thy name.*" (1) The word "hallowed" means to render or pronounce holy. Let Thy name be celebrated, venerated, and esteemed as holy everywhere. (2) This recognizes that God's name must be revered (Psa. 111:9; Heb. 12:28). (3) Not only do some fail to reverence God's name, but they show disrespect in an outright manner by taking it in vain (Ex. 20:7).

4. "*Thy kingdom come.*" (1) The kingdom is the church (Matt. 16:18,19). (2) Jesus did not come to establish an earthly kingdom (Jno. 18:36). (3) The kingdom was established during the lifetime of some of the disciples who lived 1900 years ago (Mk. 9:1). (4) It was established on Pentecost following the resurrection of Christ (Acts 2). (5) Members of the church at Colosse were in the kingdom (Col. 1:13). This is true of church members everywhere. Things equal to the same things are equal to each other. (6) This part of the prayer recognizes the church. We cannot pray for it to come, because it has already come. But we can pray for it to spread.

5. "*Thy will be done on earth as it is in heaven.*" (1) Here Jesus recognizes that God's will has priority over any man's will. (2) Jesus exemplified this principle in his own life (Jno. 5:30; Matt. 26:39). (3) Man's whole duty is to fear God and keep his commandments (Eccl. 12:13). (4) This part of the prayer is revolutionary. Henry Ward Beecher called it the "most fearful prayer" in all the world. Everyone knows that God's will is obeyed perfectly in heaven. And we are told to pray for the same thing on earth. You say these words in prayer, but what would happen if God should answer it in detail immediately? What would happen to your business? Your home? Your church relationship? Your thinking? Your speech? Your friendships? Your time? Your purse?

6. "*Give us this day our daily bread.*" (1) This recognizes God as the provider and giver of material bless-

ings (Mat. 7:9-11; Jas. 1:17). (2) It also recognizes man's dependence upon God (Phil. 4:19).

7. "*And forgive us our debts as we forgive our debtors.*" (1) This recognizes the reality of sin, the need of forgiveness from God, and the need of forgiving each other. (2) We need forgiveness from God (Jno. 8:21; Acts 8:22). (3) We need to forgive each other (Matt. 6:14,15; Col. 3:13). (4) If God forgives us as we forgive our debtors, then how many of us stand forgiven in his sight?

8. "*And lead us not into temptation.*" (1) Here we see a recognition of temptation. It is not an illusion; it is real. (2) God tempts no man (Jas. 1:13). (3) God will not suffer us to be tempted above that we are able to bear (I Cor. 10:13) — that is, if we pray to him and work with him and want a way of escape. Can you truthfully pray for a way of escape?

9. "*But deliver us from evil*" — "the evil one" (A. S. V.). (1) This recognizes Satan, his work, and his influence (II Cor 2:11; Eph. 6:11; Matt. 4:11). Jesus never made light of Satan. (2) "Resist the devil, and he will flee from you. Draw nigh to God, and he will draw nigh to you" (Jas. 4:7,8).

THE CHRISTIAN LIFE

1. *Introduction.* The most beautiful thing in the world is the Christian life. A Christian is a baptized believer (Mk. 16:16) raised to walk in newness of life (Rom. 6:3,4).

2. *It is a new life.* (1) Been born again (Jno. 3:3,5); hence, a new life (Rom. 6:3,4). (2) All things have become new (II Cor. 5:17). New name (Isa. 62:2; Acts 11:26); new speech (Col. 4:6); new attitude toward neighbor (Matt. 22:39); new spirit toward enemy (Matt. 5:44); new business and social rule (Matt. 7:12); new way to spend the Lord's day (Heb. 10:25); new way to use money (II Cor. 8:1-5). (3) It is the state or the land of beginning again.

I wish there were some wonderful place
 Called the Land of Beginning Again,
 Where all our mistakes and all our heartaches,
 And all our selfish grief
 Could be dropped like a shabby coat at the door
 And never put on again.

3. *A life which revolves around Christ* (Phil. 1:21).

(1) Rear Admiral Richard E. Byrd told an interesting story concerning his first expedition to the South Pole. He left his small isolated hut one day for a brief trip of exploration, and then in a sudden blizzard he became hopelessly lost. There was nothing to give him any sense of direction. He had a long pole which he always carried to feel if there were holes in the ice; so he stuck it in the snow and tied a scarf to it. He said, "That was my center. If I failed to find my hut, I could return to the center and try again. Three times I tried and failed. In the fourth attempt, I stumbled upon my hut." (2) There must be a home port, a point of reference. In mathematics it is found in the decimal point. In language it is found in the basic rules of grammar. In religion it is found in Christ. Our standards come from him. I Pet. 2:21; I Cor. 11:1; Heb. 1:1,2.

4. *A growth to be made* (I Pet. 2:2). (1) Grow in knowledge (II Pet. 1:5). (2) Grow in good works (Gal. 6:10). (3) Grow in giving (II Cor. 8:7). (4) Grow in soul-winning (Prov. 11:30; Jno. 1:40-42). Will there be souls in heaven because you lived? (5) Grow in diplomacy (Matt. 10:16). At a dinner a woman said, "Doctor, can you tell me who that horrible looking man is over there?" The doctor replied, "I can; that is my brother." There was an awkward pause while the woman racked her brain for something to say. She then stammered, "Oh! How silly of me not to have seen the resemblance." Use diplomacy in visiting the sick and talking to the lost. (6) Grow out of childish things (I Cor. 13:11).

5. *A race to be run* (I Cor. 9:24). (1) Heb. 12:1,2. A runner — light shoes, etc. Lay aside every weight: jealousy, envy, malice, hatred, evil speaking, unforgive-

ness, conceit, and indifference. (2) Persevere (Phil. 3:13, 14).

6. *A fight to be fought.* (1) There are two forces in the world. When you became a Christian you aligned yourself with Christ (Matt. 12:30). Matt. 6:24. (2) I Tim. 6:12; II Tim. 2:3; Eph. 6:11-13.

7. *A life of burdens.* (1) There is a cross to bear (Matt. 16:24). (2) Gal. 6:2. (3) An ant, carrying a big piece of straw, came to a crack in the ground. It stood for a time, as though pondering the situation, then put the straw across the crack and walked over it. What a lesson for us! The burden became the bridge for progress. Our burdens can sometimes be turned into bridges.

8. *A life in which we learn how to die* (Phil. 1:21). A young girl lay fatally ill. She was the idol of her parents; her every whim had been granted. The doctor, after examining her, whispered into the ear of the mother. The message was heard by the sick girl, who said, "Mother, you taught me to dance, to dress well, and to conduct myself well in the world, but you failed to teach me how to die."

A REJECTION OF THE COUNSEL OF GOD

Lk. 7:30

1. *A refusal to be baptized* is a rejection of the counsel of God (Lk. 7:30). (1) It is a rejection of Christ's commands (Matt. 28:19,20; Mk. 16:15,16; Jno. 3:5; Acts 2:38; 22:16). (2) It is also a rejection of Christ's example (Matt. 3:13-17).

2. *A refusal to attend worship* is a rejection of the counsel of God (Heb. 10:25). (1) It is a rejection of Christ's command (Jno. 4:23,24; Matt. 4:10). (2) It is also a rejection of Christ's example (Lk. 4:16).

3. *A refusal to take the Lord's supper* is a rejection of the counsel of God. (1) It is a rejection of Christ's command (I Cor. 11:23-29). (2) It is a rejection of Christ's example — he instituted it. (3) It is a rejection

of an approved example of the early disciples (Acts 20:7).

4. *A refusal to seek the kingdom first* is a rejection of the counsel of God. (1) It is a rejection of Christ's command (Matt. 6:33). (2) It is also a rejection of Christ's way of life (Lk. 2:49; Jno. 5:30; Matt. 26:39).

5. *A refusal to give* is a rejection of the counsel of God. (1) It is a rejection of God's command (I Cor. 16:2; II Cor. 8:7; 9:7). (2) It is also a rejection of God's example (Jno. 3:16; Rom. 5:8; Jas. 1:5). (3) God regarded it as robbery (Mal. 3:8).

6. *Conclusion:* (1) We must preach and practice the whole counsel of God (Acts 20:27). (2) It is a sin to add to or take from God's word (Rev. 22:18,19). (3) To refuse to obey is sin (Jas. 4:17).

NOT EVERYONE

Matt. 7:21-23

1. *Not everyone will be saved.* (1) Matt. 7:21-23, 13, 14; 25:31-46. (2) Many judge themselves unworthy of everlasting life (Acts 13:46). Will not be saved (Jno. 5:40; Matt. 23:37).

2. *Not everyone who is religious will be saved.* (1) This is seen in the text. (2) Why? Have not done the Father's will, as seen in the text. It is vital that we obey the Father (Jno. 5:30; Heb. 5:8,9).

3. *Not everyone who prays will be heard.* (1) This is seen in the text. (2) To pray acceptably one must keep God's commandments (I Jno. 3:22), ask in faith (Jas. 1:6,7), pray in harmony with God's will (I Jno. 5:14), pray in Jesus' name (Jno. 14:14), and pray with the right motive in mind (Jas. 4:3).

4. *Not everyone who works will be saved.* (1) The Pharisees worked (Matt. 23). (2) For works to avail a blessing they must be motivated by love (Gal. 5:6; I Cor. 13:1-3).

5. *Not everyone in Christ's church will be saved.* (1) The Lord will gather out of his kingdom the ones who offend (Matt. 13:41,42). (2) The ten virgins represent

citizens in the kingdom, church members, but five were lost (Matt. 25:1-12)).

6. *Not everyone loves the Lord.* How do we know? They keep not the commandments (Jno. 14:15,21).

7. *Not everyone loves the truth.* If so, they would see the truth (II Thess. 2:10-12; II Cor. 4:4).

8. *Not everyone is honest.* (1) Some speak lies in hypocrisy, not honestly (I Tim. 4:1-3). (2) Some with feigned words make merchandise of souls (II Pet. 2:3). Those who do are the world's meanest racketeers.

9. *Not everyone has eyes with which he can see and ears with which he can hear.* (1) They shut their eyes and close their ears (Matt. 13:15; Acts 7:57). Prejudice has done that to many. (2) They lack good hearts (Lk. 8:15).

10. *Not everyone wants to do right.* Some love darkness instead of light (Jno. 3:19).

11. *Conclusion.* But there are some things everyone will do; for instance: (1) Stand before God in judgment (Rom. 14:12). (2) Bow the knee and confess to God (Rom. 14:11). Hence, there will be no infidels judgment day. (3) Be judged according to the Bible (Rev. 20:12). (4) "Receive the things done in his body, according to that he hath done, whether it be good or bad" (II Cor. 5:10).

SOME EVILS CHRIST SAW IN THE LIVES OF THE PEOPLE

1. He saw *selfishness* in the life of Herod (Matt. 2). Herod was so selfish that he killed the little children to protect his own interest. Christ was unselfish (Matt. 20:28). (2) The Good Samaritan was unselfish (Lk. 10:30-37). (3) Paul was not self-centered (Phil. 3:4-8). (4) Christianity demands unselfishness (Matt. 22:39; Phil. 2:4).

2. The Saviour saw *carelessness* in the lives of his own mother and foster father (Lk. 2:41-52). They went for a whole day carelessly supposing Jesus was in their crowd.

Often we are careless with our most precious valuables: children, love, friendships, etc.

3. Jesus saw *inappreciation* in the lives of his neighbors (Matt. 13:53-58). (1) It caused Jesus to say, "A prophet is not without honor, save in his own country." (2) We may get so close to a thing that we cannot appreciate it; like the man who said, "I cannot appreciate the forest for the trees." Distance lends enchantment and value. An elder once said, "We are having Brother So-and-So to come and hold us a meeting. He must be a good preacher because he lives so far away."

4. Christ saw *insincerity* in the conduct of some of his professed followers (Jno. 6:26). (1) They were following for the loaves and fishes. (2) In Matt. 6 Jesus teaches sincerity as the true motive in giving, praying, and fasting.

5. Our Lord saw *partyism and ceremonialism* in the religious life of the Pharisees (Matt. 23). (1) Our service to God must come from the heart (Matt. 22:37; Jno. 4:23,24). (2) Religious service from the lips out is in vain (Matt. 15:7,8).

6. He saw *self-righteousness* paraded in the lives of the Pharisees. It caused him to speak a parable (Lk. 18:9-14). (1) Far from being self-righteous, the beloved John said, "If we say that we have no sin, we deceive ourselves" (I Jno. 1:8). (2) At best, we can only say, "I count not myself to have apprehended" (Phil. 3:13).

7. He saw *betrayal* in the life of Judas (Matt. 26:14-16, 47-50). (1) In deception, Judas kissed Jesus. That which could have been the whitest — the kiss — has gone down in history as the blackest because the motive was wrong. (2) Nations have their Benedict Arnolds, and Christianity has its Judases. (3) Many today betray Jesus for money, popularity, and the pleasures of sin.

8. Christ saw *lying* in the testimony of the false witnesses (Matt. 26:60). They misrepresented Jesus. Many false witnesses misrepresent him today by misrepresenting his word (II Pet. 2:1-3).

9. Jesus saw the *crookedness of politics* in the judg-

ment of Pilate (Matt. 27:17-26). Statesmanship follows the course of right. Politics pursues the course of popularity. Let us keep pressure methods and political maneuverings out of the church.

10. The Son of God saw *cruelty* in the lives of the soldiers (Matt. 27:27-31). Cruelty! No tenderness! No sympathy! Eph. 4:31,32; I Pet. 3:8,9.

11. Christ saw *ingratitude* in the lives of the nine lepers who had been healed (Lk. 17:11-19). Only one returned to thank him. Most people are not very grateful. They think they have everything coming to them. Col. 2:7; 3:15.

“TAKE IT EASY”

Lk. 12:19; Amos 6:1

1. *Introduction.* (1) “Take it easy” is an oft-repeated expression. Many say it thoughtlessly. But it does reflect the philosophy of the age. It is the only principle of life some people have. Jesus told of a man whose greatest ambition was comfort and ease (Lk. 12:19). (2) In this great ease age we have labor saving gadgets galore. Life was hard and rugged for our fathers. It is soft and easy for us. (3) This philosophy of ease has affected all realms of life.

2. *It has affected our political thinking.* (1) It has converted strong statesmen into cheap politicians who are in mad competition with each other to see who can offer the voters the most for nothing. Past civilizations have decayed and perished because their peoples became indolent, careless, and wicked. (2) Our American heritage stands in jeopardy today because our people wish to “take it easy”; because they love ease more than strength, and pleasure more than God. II Tim. 3:4. The men who paid the price for American liberty were hard working men with strong religious convictions. (3) In this ease age crime, licentious living, and wickedness are having a field day. A nation with a philosophy of work did not need

so many courts, jails, and penitentiaries. As idleness increases, sin increases (I Tim. 5:13).

Ill fares the land,
To hasten ills a prey,
Where life gets easy,
And men decay.

(4) From the very beginning God has commanded men to work (Gen. 2:15; 3:19; Ex. 20:9; Eph. 4:28; II Thess. 3:10).

3. *This "take it easy" complex has invaded the realm of training and disciplining children.* (1) To some the school has become a place for play and fun rather than a place to develop thinking and increase knowledge. (2) The philosophy is: make life easy for them. Very little discipline. No more hickory tea! No wonder we have developed a generation of softies who worship ease and pleasure. (3) Prov. 22:1; 29:15; Lk. 2:52.

4. *This "take it easy" attitude has also invaded religion.* (1) Churches have gone all out to please men who want an easy religion. A rugged religion which demands the best there is in a person has become unpopular. The majority prefer to be coddled, lulled, and soothed. Consequently, many churches are in a mad race to see which one can make religion the easiest instead of the safest. Standards are recklessly lowered in the hope of drawing the crowds. (2) This spirit is described in II Tim. 3:1-5. This is seen in that men are told to "believe what you wish; join the church of your choice; and be baptized as you please." A life of cross-bearing is not encouraged (Matt. 16:24); contrariwise, it is rather understood that they "have it made." I Cor. 10:12; Heb. 3:12; Jno. 15:2,6. The spirit of the day is further seen in the general practice of building church auditoriums that can accommodate only about one-fourth of the membership, because the other three-fourths do not go anyway. Acts 20:7; Heb. 10:25. And it is out of the question to discipline them (II Thess. 3:6); instead, the churches operate on the basis that these poor sinners must be permitted to live as they please, lest they be discouraged and

antagonized. A life of ease! (2) Many wanted a life of ease during the first century. Their only interest was materialism. Some followed Jesus only for the loaves and fishes — a life of ease (Jno. 6:26). Jesus related a story of a man whose only thought was ease and called him a fool (Lk. 12:15-21). This is why the one-talent man failed (Matt. 25:14-30). This was the spirit that overcame the church at Laodicea (Rev. 3:15-17). (3) A love for ease keeps many in the church from doing things today: from teaching classes; from doing personal work; from attending services; from helping others. (4) Christianity is not a religion of ease. It was not easy for Jesus to die for us. It was not easy for Paul to go through those trying experiences spoken of in II Cor. 11:23-28. It was not easy for Peter and John, who were threatened, to say, "We must obey God rather than men" (Acts 5:29). We see from the following passages that Christianity is not a religion of ease: Matt. 16:24; II Tim. 3:12; Rom. 12:1,2; Eph. 6:11,12. Christianity offers no special sales or bargain days. There are no marked down prices. We must pay the full price.

IF

1. There are *many "ifs"* in life, and there are many "ifs" in religion.

2. A man is a good minister, *IF he puts his brethren on guard* against the danger of apostasy, etc. (I Tim. 4:6). God's people have never remained faithful for long periods of time. There is only one faith (Eph. 4:5). We should contend for it (Jude 3). Every generation should be indoctrinated (I Tim. 4:16; Deut. 6:7; 11:19).

3. The Lord will deny us, *IF we deny him* (II Tim. 2:12). Matt. 10:33.

4. A person's religion is vain, *IF he "bridleth not his tongue"* (Jas. 1:26). Jas 1:19; Lev. 19:16; I Pet. 3:10.

5. *"IF ye have respect to persons, ye commit sin"* (Jas. 2:9). Jas. 2:1,4; I Pet. 1:17; Acts 10:34. God respects faith and principles, not persons.

6. "Even so faith, *IF it hath not works*, is dead being alone" (Jas. 2:17). Jas. 2:19,24,26; Gal. 5:6; Jno. 12:42,43.

7. We ought to say that we shall live and do this or that, *IF the Lord will* (Jas. 4:15). The rich fool made the mistake of not living this way (Lk. 12:16-20). Jas. 4:13,14.

8. "*IF ye do these things*, ye shall never fall" (II Pet. 1:10). The things mentioned in the previous verses. A Christian can fall (I Cor. 10:12; Heb. 3:12; Gal. 5:4; Jno. 15:6). But it can be prevented, and will be, *IF* — .

9. "*IF we walk in the light*, as he is in the light, we have fellowship one with another, and the blood of Jesus Christ his Son cleanseth us from all sin" (I Jno. 1:7). Christ's shedding his blood is not enough to cleanse us (Heb. 2:9). Our desire to be cleansed is not enough. We must walk in the light, if we are cleansed. Jno. 8:12; Psa. 119:105.

10. "*IF we say that we have no sin*, we deceive ourselves" (I Jno. 1:8) — not God, for he knows. Rom. 3:23; Gen. 8:21. This places those who claim sinless perfection in a bad light.

11. "*IF we confess our sins*, he is faithful and just to forgive us our sins . . ." (I Jno. 1:9). This has reference to erring children of God instead of aliens. Jas. 5:16; Acts 8:22.

12. "And hereby do we know that we know him, *IF we keep his commandments*" (I Jno. 2:3). No supposition or guess work. I Jno. 2:4-6. This is the way we prove our faith (Jas. 2:18).

"LET NO MAN DECEIVE HIMSELF"

I Cor. 3:18

1. *Introduction.* The greatest deception in the world is self-deception. Many are guilty.

2. *Man may deceive himself by minimizing his sins* (I Jno. 1:8). (1) Some even claim sinless perfection. A lady in Fort Worth a few years ago said, "I am as good

as Jesus Christ and getting better every day" — self-deception. (2) We deceive ourselves by seeing the mote in a brothers eye and never seeing the beam in our own (Matt. 7:3-5).

3. *We may deceive ourselves by thinking God is like man* (Psa. 50:21). (1) A common form of idolatry is to make not a metal but a mental image of God to conform to man. (2) Adam and Eve could hide from each other; so they thought they could hide from God (Gen. 3:10; Prov. 15:3) — thought God was like man. (3) Man can bribe man; so he thinks he can bribe God. I Sam. 15:22. (4) Man thinks one religion is as good as another; so he thinks God feels this way. Isa. 55:8,9; Matt. 15:13,14.

4. *One may deceive himself by surmising a way is right when it is wrong* (Prov. 14:12). A classic example of this form of self-deception is Saul of Tarsus (Acts 26:9).

5. *When a man attempts to change the Bible he has only deceived himself.* (1) Through the centuries many deceived people have requested a perverted word (Isa. 30:10). Paul warned of these poor deluded people who have itching ears (II Tim. 4:3,4). (2) Martin Luther did not like the way Romans 5:1 reads; so he wrote the word "only" between the lines in the verse. (3) But at the judgment we shall be judged by the Bible in its completeness (Rev. 20:12). To change it now is mere self-deception.

6. *Man may deceive himself by thinking he can sow one thing and reap something else* (Gal. 6:7). (1) Reaping as one has sown is a universal law. It is no less true in spiritual matters. (2) Ahab thought he could escape the reaping by disguising himself, but he was deceived (I Kings 21:19; 22:3,30-38).

The tissue of the life to be
 We weave with colors all our own,
 And in the field of destiny
 We reap as we have sown.

—John Greenleaf Whittier

7. *Man may deceive himself by following a lip religion* of ceremonialism which has no heart in it (Matt. 15:8). The Phar'ees were deceived in this manner (Matt. 23).

8. *A person may deceive himself by thinking he is more important than he really is* (Gal. 6:3). The crowd soon detects a phony. He has deceived nobody but himself.

9. *Man may deceive himself by placing faith in tomorrow* (Jas. 4:13,14). This was true of poor Felix (Acts 24:25). Slaves of tomorrow! Slaves of tomorrow! What a pitiful, hopeless lot they are. Chained to tomorrow, nothing is done; for all good intentions die in the realm of tomorrow.

10. *Man may deceive himself by talking too much* (Jas. 1:26). An unbridled tongue nullifies religion and renders it vain. I Pet. 3:10.

SIN

1. *What it is.* (1) Universal (Rom. 3:23). I Jno. 1:10. (2) Transgression of law (I Jno. 3:4). (3) Omission of duty (Jas. 4:17). (4) Often presumptuous (Psa. 19:13). The sin of Nadab and Abihu (Lev. 10:1). (5) Rebellion against God (Deut. 9:7). I Sam. 15:23. (6) Religious acts not of faith (Rom. 14:23). (7) Comes from the heart (Matt. 15:19). Prov. 4:23. (8) The fruit of lust (Jas. 1:14,15). (9) Works of the flesh (Gal. 5:19-21). (10) Works of darkness (Eph. 5:11). In contrast, Jesus is light (Jno. 8:12). (11) Deceitful (Heb. 3:13). (12) Is of the devil (I Jno. 3:8). (13) A progressive thing (Psa. 1:1). The progressiveness of sin is seen in the life of Peter who boasted, followed afar off, denied, cursed, and swore. (14) Something enjoyable for a season (Heb. 11:25). (15) Separates man from God (Isa. 59:2). (16) Bars from heaven (Jno. 8:21).

2. *Things we cannot do.* (1) Cannot throw the blame of our sins on others. Adam and Eve could not (Gen. 3:12,13); neither could Aaron (Ex. 32:22-24). Each must account for self (Rom. 14:12). Cannot change the wages

of sin (Rom. 6:23). Jas. 1:15; Rev. 20:14,15. (3) Cannot redeem ourselves (Eph. 1:7). (4) Cannot forgive self (I Jno. 1:7).

3. *Things we can do.* (1) Abhor sin (Rom. 12:9). (2) Avoid its appearance (I Thess. 5:22). (3) Watch and pray (Matt. 26:41). (4) Die to sin (Rom. 6:2). (5) Become free from sin (Rom. 6:17).

THE SAYINGS OF SATAN

1. *Introduction.* We can profit from a study of words spoken by Satan. That is why they were recorded.

2. *Sayings spoken to Eve.* (1) He said, "Yea, hath God said, ye shall not eat of every tree of the garden?" (Gen. 3:1). He knew what God had said. This was one of his wiles (Eph. 6:11). (2) Next, he said, "Ye shall not surely die" (Gen. 3:4). He contradicted God's word. "He is a liar" (Jno. 8:44). For the first time, the doctrine of the impossibility of apostasy was preached — in other words, "Go on and eat; you can't fall."

3. *Sayings relative to Job.* "When the sons of God came to present themselves before the Lord, and Satan came also among them" (Job 1:6). He always does. He comes to make trouble. (1) In answer to the Lord's question, "Whence comest thou?" he said, "From going to and fro in the earth, and from walking up and down in it" (Job 1:7). Some think Satan is off in the stratosphere. But he is right here on earth, working it (I Pet. 5:8). Just one trip to town and back will convince you of this. (2) Satan indicted Job by saying, "Doth Job fear God for nought?" (Job 1:9-11). Satan thought every man has his price. He thought bankruptcy would cause Job to deny God. Bankruptcy does affect some people's religion. Serving God out of ulterior motives is no service at all. Some serve for reasons which are political, business, etc. He who serves God for such wages will quit when Satan raises the pay. Satan was wrong about Job (Job 1:21, 22; 2:3). (3) Satan said, "Skin for skin, yea, all that a man hath will he give for his life. But put forth thine

hand now, and touch his bone and his flesh, and he will curse thee to thy face" (Job 2:4,5). This is not so. There are some things more important than life; for instance, the soul (Matt. 10:28; II Tim. 4:6-8), honor (Prov. 22:1), etc. Many persons have had to fight Satan as he worked through one's wife or husband.

4. *Sayings spoken to Jesus.* (1) "If thou be the Son of God, command that these stones be made bread" (Matt. 4:3). The devil's "if" struck at the faith of Christ. This temptation was distrust. It appealed to the present appetite, to the impulse of the moment. (2) Next, Satan said, "If thou be the Son of God, cast thyself down: for it is written . . ." (Matt. 4:6). This was a temptation to presumption and over-trust. The quoted Scripture is from Psa. 91:11,12 and applies to man generally. This shows that Satan's head is full of Scripture and that his heart is empty of it. It also shows that the devil can quote Scripture to try to prove a point. So can his servants (II Cor. 11:14,15). (3) Satan's next saying: "All these things will I give thee, if thou wilt fall down and worship me" (Matt. 4:9). This was a temptation to realize the dreams which the Jews entertained, that of political power. Satan offers certain things in return for service to him. Many sell out to him. Christ said, "What shall a man give in exchange for his soul?" (Matt. 16:26).

ONE

1. One God (Eph. 4:6). Ex. 20:3; Jno. 4:23.
2. One Lord (Eph. 4:5). Jno. 1:1,2.
3. One Spirit (Eph. 4:4). Jno. 14:26.
4. One faith (Eph. 4:5). Jude 3.
5. One baptism (Eph. 4:5). Bible speaks of six baptisms: Baptism unto Moses (I Cor. 10:2). Baptism of suffering (Mk. 10:38). Baptism in fire (Matt. 3:11). Baptism of the Holy Spirit (Matt. 3:11). John's baptism (Mk. 1:5). Baptism of Great Commission (Mk. 16:15,16). The latter is the one baptism for men to obey today. It is a burial in

water (Rom. 6:3,4), and is for the remission of sins (Acts 2:38).

6 One body (Eph. 4:4). Eph. 2:16; 1:22,23; Jno. 17:20,21.

7. One mediator (I Tim. 2:5).

8. One blood (Acts 17:26).

9. To offend in one point is to be guilty of all (Jas. 2:10).

10. One mind (Phil. 2:2). To have one mind we must follow the Scriptures — one rule (Phil. 3:16).

TWO

1. *Introduction.* This numeral is an important word and makes an interesting study.

2. Ten commandments were first written on *two tables of stone* (Ex. 31:18).

3. *Two are better than one* (Eccl. 4:9-12). There is strength in numbers provided there is cooperation (II Cor. 6:1).

4. *On two commandments* hang all the law and prophets (Matt. 22:37-40). The importance and characteristics of love (I Cor. 13).

5. Herod slew the *children two years of age* and under (Matt. 2:16).

6. Jesus sent the apostles on the limited commission *by two and two* (Mk. 6:7).

7. The greatest lesson on liberality concerns the widow's giving *two mites* (Mk. 12:42).

8. *No man can serve two masters* (Matt. 6:24). Matt 12:30.

9. "He taketh away the first *that he may establish the second*" (Heb. 10:9). The Jewish dispensation was taken away that the Christian dispensation could be established. Col. 2:14; Heb. 8:6-10; 9:16,17.

10. *Man is two in one: flesh and spirit* (Eccl. 12:7). II Cor. 4:16. Death is the separation of the two (Gen. 35:18; Jas. 2:26).

11. *There are two births*: that of earthly parents and later a spiritual birth (Jno. 3:3-5).

12. *There are two deaths*. The first is physical (Heb. 9:27; Psa. 90:10). The second is spiritual (Rev. 2:11; 20:14). He who is born but once will die twice; but he who is born twice and is faithful will die but once.

THREE

1. There are *three divine beings*: God, Christ, and Holy Spirit. Man is baptized into the name of all three (Matt. 28:19). Each performed a distinct work in God's plan for man.

2. *Three of the apostles* were closest to Jesus: Peter, James, and John (Matt. 26:36,37).

3. Jesus told of *three men* to illustrate who a neighbor is (Lk. 10:30-37).

4. There are *three graces that abide* (I Cor. 13:13).

5. There are *three dispensations* spoken of in the Bible: Patriarchal, Jewish, and Christian.

6. There are *three that bear record in heaven* (I Jno. 5:7).

7. There are *three that bear witness in earth* (I Jno. 5:8). (1) Spirit. Jno. 14:26; 15:26; 16:13; Jno. 6:63; Rom. 8:16. (2) Water. Rom. 6:3,4; Col. 2:12. Baptism is a silent witness to Christ for it is a form of his death, burial, and resurrection. (3) Blood. I Cor. 11:26. The Lord's supper is also a silent witness to Christ.

FOUR

1. There are *four gospels*. They were written to create faith in man's heart (Jno. 20:30,31). They tell us much.

2. *Jesus used this numeral* to teach a lesson on soul-winning (Jno. 4:35). It is easy to procrastinate.

3. *Lazarus had lain in the grave four days* (Jno. 11:17). One of Christ's greatest miracles had to do with the numeral "four." It was as easy for Jesus to raise the

dead as it was to heal the sick. If those who claim miraculous powers today have Jesus working through them, they could raise the dead, too. The Lord is all-powerful.

4. The soldiers divided the *garments of Jesus into four parts* (Jno. 19:23). Men today wish to divide his spiritual body into parts. Jno. 17:20,21; Eph. 4:3.

5. Philip had four daughters who prophesied (Acts 21:9).

6. Solomon brought us great and vital lessons from *four little things* (Prov. 30:24-28).

FIVE

1. "*Five of you shall chase a hundred*" (Lev. 26:8).

(1) This shows what a few can do with God on their side. (2) Numbers are important, but the balance of power is not in numbers; neither is it always in swords and spears (I Sam. 17:47).

2. *David selected five smooth stones* for his fight with Goliath (I Sam. 17:40). This shows preparation. Solomon referred to ants to teach us preparation (Prov. 30:25).

3. *Jesus took five loaves and two fishes* and fed the multitudes (Matt. 14:17). It was a miracle. Which one had faith? Jesus? or the loaves and fishes? The one who performed a miracle had to have faith.

4. *In the parable, one man was given five talents* (Matt. 25:15,16). He had to account for more than the person given one talent. So responsibility equals response to ability.

5. "*I had rather speak five words with my understanding, that by my voice I might teach others also, than ten thousand words in an unknown tongue*" (I Cor. 14:19). (1) Speaking in an unknown tongue has ceased (I Cor. 13:8; Jas. 1:25). (2) The practical lessons for teachers today is to speak in language easily understood.

6. *There were five wise and five foolish virgins* (Matt. 25:1-13).

SIX

1. *“There are six things which Jehovah hateth”* (Prov. 6:16-19). (1) “A proud look.” Prov. 16:18; I Jno. 2:15-17; Jas. 4:6; Lk. 8:14. (2) “A lying tongue.” Prov. 12:22; Jno. 8:44. (3) “Hands that shed innocent blood.” Under O. T. laws God ordered certain guilty ones to be put to death; but God has always been a defender of the innocent. (4) “A heart that deviseth wicked imaginations” — lying, plotting, scheming, etc. (5) “Feet that are swift in running to mischief” — he who swiftly runs to mischief. (6) “A false witness that uttereth lies.” Ex. 20:16. Some bear false witness by slurs and imaginations. (7) The seventh is an abomination to Him — “He that soweth discord among brethren.” Rom. 14:19; Matt. 5:9; Prov. 20:3.

2. *God worked six days* (Gen. 1:31 — 2:3). (1) Ex. 20:8-10. (2) Under the Christian dispensation we meet for worship on the first day of the week (Acts 20:7; I Cor. 16:2). (3) Man needs a day of rest. Even the soil needs rest.

3. *There are six steps in plan of salvation for the alien.* (1) Hear (Acts 18:8; Rom. 10:13,14). (2) Understand (Acts 8:30; Matt. 13:15). (3) Believe (Mk. 16:16; Heb. 11:6). (4) Repent (Lk. 13:3; Acts 2:38). (5) Confess (Matt. 10:32; Rom. 10:10). (6) Be baptized (Acts 22:16; I Pet. 3:20,21). Then, of course, the person saved from alien sins must do certain things to be eternally saved (II Pet. 1:5-10).

SEVEN

1. *Seven years of great plenty; seven years of famine* (Gen. 41:29,30). (1) One extreme often follows another. (2) It is also easy to go from one extreme to another in church work.

2. *Naaman was told to wash in Jordan seven times* (II Kings 5:10). (1) That was an act of faith — not a new cure for leprosy. (2) Likewise baptism for the re-

mission of sins (Acts 2:38) is salvation by faith (Mk. 16:16.).

3. *Children of Israel were commanded to march around Jericho seven times* on the seventh day (Josh. 6:1-4). (1) That was not a marching or dizzy religion, but a religion of faith. They obeyed because they believed. (2) Only an active, obedient faith is rewarded (Jas. 2:24,26).

4. *Seven churches in Asia* (Rev. 1:4). These were congregations. But there is only one body or universal church. Matt. 16:18; Eph. 2:16; 4:4; Jno. 17:20,21.

5. *Shall we forgive seven times* (Matt. 18:21,22)? Matt. 6:12,14,15; Col. 3:13.

6. *Woman with seven husbands* (Matt. 22:23-30). "They neither marry, nor are given in marriage" in heaven. A man jokingly said, "That's what makes it heaven."

7. *Seven men were selected to serve tables* (Acts 6:3). They had to meet certain qualifications. If we want to work for the Lord, we must qualify.

8. *There are seven things to add to the faith* (II Pet. 1:5-10). This will keep us from falling.

GOOD PEOPLE

1. *Introduction.* The popular conception throughout the land is that all people are good people. In some respect, perhaps this is so. At least, they are good if we look at it as follows:

2. Some are good — but *no good*. (1) They are a menace to society, criminals. The Bible teaches us to obey the laws of the land (Rom. 13:1). (2) Among this class, there are those who are cold and indifferent to the needs of others; they are selfish and self-centered. II Tim. 3:1-5. (3) Also, in this class there are those who have forgotten that God intends for man to work, tramps, those who expect to get by without making a contribution to society; they are parasites; they think the world owes them a living. I Thess. 4:11; II Thess. 3:10.

3. Some are good — but *good for what?* (1) These folk do no harm in a positive way, but what good do they do? They do no good for the church. If the church had to depend on them, it would not be long until the bats would take over the buildings. Neither are they a blessing to the community. They do not aid the sick and the suffering. They live in a little world that revolves around self. (2) They need to learn that life has positive duties as well as negative ones (Matt. 7:12; 22:37-39; Phil. 2:4). (3) The one-talent man in the parable was held responsible for what he did not do (Matt. 25:24-30). (4) The foolish virgins in another parable were lost because of what they did not do (Matt. 25:1-12). (5) The subject of doing for others will come up at the judgment (Matt. 25:41-46).

4. Some are good — but *good to be seen of men.* (1) The Pharisees were good to be seen of men. Jesus often rebuked them for their proud show and outward display of religion (Matt. 6:1,6,16; 23:5,14,27,28). (2) The old hypocrisy is to act better than what you are. The new hypocrisy is to try to impress the wicked by acting meaner than what you really are.

5. Some are good — *good in their own minds.* (1) In the parable, the Pharisee who went up to pray belonged to this group (Lk. 18:9-14). (2) This attitude makes the person his own little god with his own standard (Jer. 10:23).

6. Some are good — *morally good.* (1) Such people live good moral lives; are good neighbors; are good citizens; are an asset to the community in many ways. (2) But they have no promise of eternal life because they have not obeyed the gospel (Rom. 1:16) and are not in the body or church (Eph. 2:16; 5:23).

7. Some are good — *good for the cause of Christ.* (1) Good to attend services (Acts 20:7; Heb. 10:25). (2) Good to work for the Lord (Phil. 2:12; Jas. 2:18). (3) Good to give (I Cor. 16:2; II Cor. 8:1-5). (4) Good example in living (I Cor. 11:1). (5) Good influence (Matt. 13:33; Rev. 14:13).

GOOD PEOPLE

1. *Introduction.* Many good people will be condemned — not because they were not good — but for other reasons. Jesus taught this so plainly in many of the parables; for instance:

2. *The great supper* (Lk. 14:16-24). (1) Condemned not because they were bad people, but because they refused to come to the supper. (2) "And ye will not come to me that ye might have life" (Jno. 5:40). Jno. 14:6.

3. *The two sons* (Matt. 21:28-32). (1) The condemned boy was a good boy in many respects. He said that he would work in the vineyard. Condemned because he said and did not. Good intentions will not suffice. (2) Pharisees (Matt. 23:3).

4. *The sower* (Matt. 13:18-23). (1) All were good people, but: A. Wayside hearer allowed Satan to snatch word out of his heart. B. Stony-ground hearer was offended by tribulation or persecution. C. Thorny-ground hearer was overcome by the cares of the world and deceitfulness of riches. (2) Condemned not because they were bad, but because they did not bring forth fruit (Matt. 3:8).

5. *Talents* (Matt. 25:14-30). (1) One was condemned because he was slothful and afraid — hid his talent. (2) God called this wickedness (Matt. 25:26).

6. *The unjust steward* (Lk. 16:1-12). (1) No doubt he was what the world would call a good fellow, but he wasted his master's goods. (2) We are stewards.

7. *Rich fool* (Lk. 12:15-21). (1) He was not a bad man; but, in laying up treasures for himself, he neglected to lay up treasures in heaven (2) Many good people are foolish.

8. *The Pharisee and the publican* (Lk. 18:9-14). (1) The Pharisee was a good man — prayed, fasted, gave tithes, and refrained from doing evil. He was condemned because he trusted in himself that he was righteous and despised others. (2) Man must be humble (Matt. 18:1-4).

9. *Virgins* (Matt. 25:1-13). (1) Foolish virgins were good, but did not make enough preparation. (2) This will condemn many at the judgment.

IS THE DEVIL A FOOL?

1. *Introduction.* (1) The devil is a wicked spirit, a real personality, not a myth. (2) Neither Christ nor any other inspired person ever made light of Satan. Rather, they recognized him and his evil work, and warned against him (Jas. 4:7). (3) There are many doctrines in the world today. It will be helpful to study some of them in the light of Satan's work. Thus we ask, "Is the devil a fool?"

2. *If universalism is true*, the devil is a fool for working to get souls. (1) Jesus said, "Simon, Simon, Satan hath desired to have you, that he may sift you as wheat" (Lk. 22:31). He desires all of us. (2) Universalism is not true (Matt. 7:13,14, 21-23; II Thess. 1:8,9; I Pet. 4:17; Gal. 6:7,8; Matt. 25:31-46). So the devil knows what he is doing.

3. *If the doctrine of election and predestination is true*, then the devil is a fool to be engaged in his business. (1) He would already have you and could not lose you, or would not have you and could not get you. (2) This doctrine is not true (Matt. 11:28-30; Acts 2:40; Acts 13:46; II Pet. 1:10). So the devil is smart.

4. *If there is no hell*, the devil is a fool for working to get people to go there. (1) There is a hell (Rev. 20:10; Matt. 3:11; Jno. 15:6; Matt. 13:41,42). (2) The devil will be there (Matt. 25:41). So the devil is no fool.

5. *If there is no power in God's word*, then the devil is a fool for stealing it out of man's heart. (1) He steals the Word from man's heart (Lk. 8:12). (2) There is power in the Word (Jas. 1:21; I Pet. 1:23; Matt. 13:3-8, 18-23). Satan knows of this power while many preachers do not; he is smarter than they; he is no fool.

6. *If the children of God cannot so sin as to be eternally lost*, then the devil is a fool for trying to get them. (1) He does try (I Pet. 5:8; Eph. 6:11; Lk. 22:3; Acts 5:3). (2) A child of God can sin and be lost (Heb. 3:12; I Cor. 10:12; Gal. 5:4; Matt. 13:41,42; Jno. 15:6). So the devil is smart.

7. *If one religion is as good as another*, then Satan is a fool for engaging in religious business. 1) He does en-

gage in religious activities; has his synagogues (Rev. 2:9; 3:9); has his ministers (II Cor. 11:14,15). (2) One religion is not as good as another (Acts 4:12; Gal. 1:8,9; Matt. 15:9,13,14). So the devil is not a fool.

ARE WE FOOLS?

1. If we are *atheists*, we are (Psa. 14:1). Man can deny the Lord now, but later he must confess him (Rom. 14:11).

2. If we are *egotistical*, we are (Rom. 1:22). A fool cannot be told anything, because he "is right in his own eyes" (Prov. 12:15).

3. If we are *disobedient to God's word*, we are (Matt. 7:24-27). It is self-deception to hear the word and not do it (Jas. 1:22).

4. If we *trust in riches*, we are (Lk. 12:15-20). I Tim. 6:17.

5. If we are *quarrelsome*, we are (Prov. 20:3). Rom. 14:19.

6. If we *walk uncircumspectly*, we are (Eph. 5:15). To walk circumspectly means to walk carefully, watchfully, like some people walk in the night through a graveyard.

7. If we are *disobedient to parents*, we are (Prov. 15:5). Obedience to parents is a mark of good sense (Eph. 6:1-3).

8. If we are *slanderers*, we are (Prov. 10:18).

Who steals my purse steals trash —
But he that filches from me my good name,
Robs me of that which not enriches him,
And makes me poor indeed.

—Shakespeare

9. If we *mock sin*, we are (Prov. 14:9). Pharaoh mocked the Lord (Ex. 5:2). We shall reap what we sow (Gal. 6:7,8).

10. If we are *unprepared to meet the Lord*, we are (Matt. 25:1-13). II Pet. 3:10-14.

THE VALUE OF THE BIBLE

1. *Introduction.* An infidel who was a soap manufacturer once said to a preacher, "That Bible you preach from is a failure in the world, because look at all the sinful people." Just at that time a little boy with a dirty face crossed the sidewalk in front of them and the preacher said, "That soap you make is a failure; look at all the dirty people in the world." The manufacturer said, "That is not the fault of the soap; the trouble is they haven't used it." The preacher replied, "Now you have the point. There are many sinful people in the world, but it is not the fault of the Bible; they haven't used it."

2. *Realms in which the Bible has no special values.* (1) It has no value as a charm or relic. Its mere presence — never read or obeyed — will not bless. It is not to be used as the believers in witchcraft use a horseshoe, or as the superstitious person uses his relic or crucifix. Its value is found in obedience to it. (2) The Bible has no special value as a wedding accessory for a bride. Carrying a Bible at your wedding does not necessarily mean that your marriage is founded upon the Bible.

3. *The value of the Bible.* (1) It makes persons better, because it has a moral code that is elevating. Atheism has never changed a person from immorality to morality. Judges, understanding the power of the Bible, often parole a juvenile delinquent to someone with an agreement that he attend Bible study every week. Isaac Walton, English author, said of the Bible, "Every hour I read you it kills a sin or lets a virtue in to fight it." (2) The value of the Bible is seen in that it blesses nations (Prov. 14:34; Psa. 9:17). America's greatness is due to the influence of the Bible. Andrew Jackson said, "That Book is the rock upon which this republic rests." Daniel Webster said, "If we abide by the principles taught in the Bible our country will go on prospering, but if we and our posterity neglect its instruction and authority, no man can tell how sudden a catastrophe may overwhelm us and bury us and our glory in profound obscurity." (3) Tells us of God (Gen. 1:1). (4) Tells us of our origin (Gen. 2:7), our ob-

ligations (Eccl. 12:13), and our destiny (Eccl. 12:7). (5) Creates faith (Jno. 20:30,31). (6) Pricks and cuts the hearts of men (Heb. 4:12; Acts 2:37). (7) Affects the conscience and makes people restless in their sins (Acts 2:37). (8) Furnishes us unto every good work (II Tim. 3:16,17). (9) Helps us in every time of need: in times of want (Matt. 6:25-31); in times of plenty (I Tim. 6:9, 10,17-19); in times of sorrow (Jno. 14:1-4); and in times of death (Psa. 23). (10) It tells us how to live and how to die (Phil. 1:21).

THE VALUE OF THE SOUL

Mk. 8:36,37

1. *We are living in a commercial age in which values are discussed very freely.*

2. *The soul is more valuable than the world* (Mk. 8:36,37). Jno. 6:27; Matt. 10:28.

3. *When you see a Babe in a manger in Bethlehem* (Matt. 2), you are given a glimpse of the value of the soul; for He came to save the soul. Matt. 1:21; Lk. 19:10; Jno. 3:17.

4. *When you read the story of the lost sheep*, you better understand the value of the soul (Lk. 15:3-7).

5. *The story of the Prodigal Son* shows the value the Father places upon a lost soul (Lk. 15).

6. *The story of the rich man and Lazarus* teaches the everlasting value of the soul (Lk. 16:19-31).

7. *When you hear Christ pray in Gethsemane* (Matt. 26:36-56), you hear words which testify to the value of the soul.

8. *When you see the crucifixion* (Matt. 27:26-54), you see a scene which pictures the value of the soul. Rom. 5:8; I Cor. 15:2.

9. *When you see Him ascending into heaven* (Acts 1:9-11), you see more proof of the great value of the soul. Jno. 14:1-6.

10. *When we take a look at the judgment* (Matt

25:31-46), we are impressed with the importance of the soul. Rev. 20:12, 14, 15.

11. *You can no more estimate the value of the soul than you can estimate the value of going to heaven and escaping hell.*

12. *Death reminds us of the eternal value of the soul.* Heb. 9:27; Eccl. 12:5,7.

THE VALUE OF THE LOCAL CHURCH

1. *Introduction.* (1) The word "church" is used in two senses: congregational and universal. (2) Some people depreciate the local church. They think only in terms of the universal church. Some do not have membership in any local church. Others see no need of sacrificing or working to build up the local church. Others never stay at home enough to build up a local church. (3) Maybe we can correct this condition, if we can get people to see that the Lord has placed a real value upon the local church.

2. *The local church is a candlestick* (Rev. 1:20). (1) Each of the seven churches in Asia was called a candlestick. A candlestick supports light. This is a wonderful compliment. (2) If the local church does not do its duty, the Lord will remove the candlestick (Rev. 2:5). (3) If upholding the light is of great value, then so is the local church; for that is what it does.

3. The local church is called a *golden candlestick* (Rev. 2:1; 1:20). Not a wooden, iron, or brass candlestick, but a golden candlestick. This shows the value the Lord puts on it.

4. The local church means so much to the Lord that *he walks in the midst of it* (Rev. 2:1). He is continually walking in the midst of the churches in spite of their faults and failures. And those seven churches in Asia had many. Some people want to get out of the church because of its faults, but Christ remains. He surely places a lot of value upon it.

5. We see the value of the local church in that it is *the divinely appointed agency to support the truth* (I Tim.

3:15). (1) Since the church is to support the truth, it must mean that the local church is to do this; for there is no legislative or executive power by which the universal church may act. Eph. 3:10. (2) If supporting the truth is important, then so is the local church; for that is a work of the local church.

6. *If doing benevolent work is important*, then so is the local church; for that is a work of the local church.

(1) The churches of Galatia were ordered to take up collections for the poor saints in Jerusalem (I Cor. 16:1-3). But it was done through the local churches. (2) Acts 11:27-30.

7. *If oversight in the Lord's work is valuable*, then so is the local church; for it is there that we have the only oversight the Lord has appointed for his church. (1) Acts 20:28; I Pet. 5:2,3. (2) There are no district or universal bishops. (3) The members of the local church are to obey its overseers (Heb. 13:17).

8. Jesus recognized the value of the local church by commanding that *personal differences*, if they cannot be settled otherwise, *be taken before the church* (Matt. 18:15-17). This must refer to the local church, for one could not take the matter to the universal church; neither could one hear the universal church.

9. *A local church meant enough to Paul* that he wrote a letter and commended a member to it (Rom. 16:1,2).

10. *Paul assayed to join himself to the disciples in Jerusalem* (Acts 9:26). Some members today are not like Paul. They wish to lose themselves in the crowd rather than join themselves unto the disciples.

THE VALUE OF INFLUENCE

I Cor. 5:6,7

1. *The power of influence*. (1) Because of the power of influence, no one goes alone to heaven or hell. (2) The church is a kingdom of influence (Matt. 13:33). (3) "And there shall be, like people, like priest" (Hos. 4:9). (4) Through influence, we use the language spoken around

us. For instance, in the South we say, "You all." However, this is a Biblical expression (I Thess: 1:2).

2. *Evil influences.* (1) Many have gone astray through evil influences (I Cor. 15:33). (2) Eve influenced Adam (Gen. 3:6). (3) Herod was influenced by "them which sat with him at meat" (Matt. 14:9). (4) Jesus warned of the influence of the Pharisees and Sadducees (Matt. 16:6,12). We must constantly guard against the influences of our religious neighbors. (5) What we read, see, and hear influences us (Prov. 23:7).

3. *Righteous influences.* (1) Each writes a gospel.

You are writing a gospel, a chapter each day,
By deeds that you do, by words that you say.
Men read what you write, whether faithless or true.
Say! What is the gospel according to you?

(2) Mother influences daughter, and father influences son (II Tim. 1:5). (3) Wife influences husband (I Pet. 3:1,2). (4) Paul had a saving influence wherever he went. A. On a ship in the midst of a storm (Acts 27). B. In jail (Acts 16:25-34). C. Made saints in Caesar's household (Acts 28:30,31; Phil. 4:22).

4. *It is a command to be a good influence* — not an optional matter. (1) We are to be salt (Matt. 5:13). (2) We are to be light (Matt. 5:14-16).

5. *Influence lives after we are dead* (Rev. 14:13).

Lives of great men all remind us,
We can make our lives sublime,
And, departing, leave behind us,
Footprints on the sands of time;
Footprints, that perhaps another,
Sailing o'er life's solemn main,
A forlorn and shipwrecked brother,
Seeing, may take heart again.

THE VALUE OF THE DOLLAR

What it will not do:

1. Will not buy redemption (I Pet. 1:18,19).
2. Would not buy the Holy Spirit (Acts 8:20).

3. Could not buy Christ's good favor or will (Rev. 3:15-18).
4. Could not buy heaven (Lk. 16:19-31). I Tim. 6:7.
5. Could not buy peace of mind for Judas (Matt. 27:3-5).
6. Could not buy happiness for Solomon (Eccl. 2:3-11). I Kings 10:23.
7. Would not heal a cripple (Acts 3:6).
8. Could not buy health (Lk. 8:43,44).
9. Cannot buy love or respect.

What it will do:

1. Will bribe (Matt. 26:15; 28:12).
2. Will buy friends for awhile (Prov. 19:4). Jas. 2:1-3. No doubt the Prodigal Son had friends as long as his money lasted (Lk. 15).
3. Will pay taxes (Matt. 17:27).
4. Will feed hungry people (Acts 2:45; 4:35).
5. Will support the gospel (Phil. 4:16).
6. Will build church buildings, buy literature, buy time on radio and television stations.
7. The Lord knew the value of the dollar; hence, he commanded us to give (I Cor. 16:2).

“WHO WENT ABOUT DOING GOOD”

Acts 10:38

1. *Introduction.* (1) The title of the sermon is a commentary on the whole life of Jesus. (2) It is an inspiration to read of his good words and deeds.
2. *At the age of twelve.* (1) Was about the Father's business (Lk. 2:49). (2) Was subject to his parents (Lk. 2:51).
3. Did good when he *was baptized* (Matt. 3:13-17). Fulfilled righteousness.
4. Did a stout-hearted thing when he *resisted the temptations of Satan* (Matt. 4:1-11). Jas. 4:7,8.
5. He did a beneficial thing when he *taught the disciples to pray* (Matt. 6:9-13).

6. He did good by *stilling the sea* for the scared disciples (Matt. 8:23-27).

7. He did good by *healing Peter's mother-in-law* (Matt. 8:14,15).

8. Did the merciful thing when he *healed the ten lepers* (Lk. 17:11-19). Only one showed gratitude.

9. Showed his *friendliness to sinners*. (1) Ate with them (Matt. 9:11,12). (2) Befriended the adulterous woman (Jno. 8:1-11).

10. Showed his bigness by *returning good for evil*. (1) Restored the ear of an enemy (Lk. 22:51). (2) Prayed for his murderers (Lk. 23:34).

11. He did the benevolent thing when he *fed the hungry multitude* (Matt. 14:15-21). Bread of life to hungry souls.

12. He did a thing of loving kindness when he *raised up* Peter who was sinking in the sea (Matt. 14:31). His hand is outstretched to us.

13. *His reputation* for doing good was so great that a woman said, "If I may but touch the hem of his garment. . . ." (Matt. 9:21).

14. Did good when he *washed the disciples' feet* (Jno. 13:4,5).

15. Did good when he *built the church* (Matt. 16:18; Acts 2).

16. Did the practical thing when he *prayed for oneness* (Jno. 17:20,21).

17. Did good *at the tomb of Lazarus*. (1) Wept (Jno. 11:35). Rom. 12:15. (2) Raised him. Proved his power over death.

18. Did the kind thing when he *blessed little children* (Matt. 19:14).

19. Did good when he *looked at Peter* (Lk. 22:61). Caused him to repent. Looks at us today.

20. Did an honorable thing when he *made his mother's earthly welfare one of his last cares* (Jno. 19:25-27).

21. Finally proved his goodness toward man by *dying for him* on the cross (Matt. 26:28).

22. He is *still doing good*. (1) Preparing a place

(Jno. 14:1-4). (2) Going with us (Matt. 28:20). (3) Serving as our High Priest (Heb. 4:14-16).

WHY THE CHURCH GREW SO FAST IN THE FIRST CENTURY

1. *Did grow fast.* (1) Acts 2:47; 4:4. (2) Growth is a conditional thing. We must comply with certain conditions or die. What did they do?

2. *They made a united effort.* (1) Acts 2:44. (2) Did not have the strife of denominationalism — many bodies, names, faiths, and baptisms — to confuse the people. Jesus' prayer (Jno. 17:20,21). (2) They stood together. Today many members spend so much time fighting each other — waste of time, energy, paper, and ink. Gal. 5:15. (3) They worked for peace (Acts 6:1; Rom. 14:19; Eph. 4:3). (4) Examples of cooperation. Three-fold cord (Eccl. 4:12). Locusts (Prvo. 30:27). Human body (I Cor. 12:25).

3. *They were steadfast.* (1) Acts 2:42; I Cor. 15:58; 16:13. (2) Unstable members weaken the church. (3) Illustration. An Indian went to a missionary and showed him some poetry he had written. There were several verses but each verse was exactly like the first. It is not much poetry, but is a good principle. It read:

Go on, go on, go on, go on,
Go on, go on, go on, go on.

4. *They believed their message.* (1) Had enough faith to speak to the lost (Col. 1:23). Unafraid (Acts 4:19,20). Paul made saints in Caesar's household (Phil. 4:22). They tried to save the people rather than please them (Gal. 1:10). (2) Their faith was so strong that it weathered them against the storms of opposition (Acts 8:4; II Cor. 11:23-28).

5. *They were sacrificial.* (1) Acts 2:45; II Cor. 8:5; 12:15; Rom. 12:1. (2) Sacrificing comes easy if one has devotion and faith. They believed in their work. Little faith is the cause of poor attendance in meetings, etc.

6. *The church was a candlestick* upholding the light. (1) Phil. 2:15; Matt: 5-14-16. (2) An unconverted church cannot uphold the light (Rev. 2:5).

CHRISTIAN IN DISPOSITION

1. *Introduction.* Disposition is the predominating bent or constitutional habit of one's mind. If sin came in degrees, surely the sins of disposition would be the worst.

2. The Christian disposition is *humble*. (1) God hates a haughty look (Prov. 6:16). (2) The pride of the Pharisees (Matt. 23:5-12). (3) Rom. 12:3. An elder got to thinking the church would die when he died. He wanted to enjoy being missed, so he failed to attend worship one week. No one even mentioned it to him. He became angry and quit the fellowship of the church. Some people are so egotistical that they have to suggest something before it is any good.

3. A prerequisite of Christian personality is *kindness*. (1) Col. 3:12. (2) Kindness is sympathy in action. The good Samaritan was more than sympathetic; he was kind (Lk. 10:30-37). (3) Not retaliatory (Rom. 12:19-21). The best way to get even with one who has wronged you is to pull him up to where you are.

4. The Christian disposition is *forgiving*. (1) Forgiveness is the scent that flowers give when they are trampled on. (2) Matt. 6:12. (3) Col. 3:13. (4) When God forgives a sin, he does not bring it up again (Heb. 10:17).

5. The Christian is *peaceable in disposition*. (1) Matt. 5:9. (2) Rom. 14:19. (3) Man said, "I'm going home and if my wife does not have a good meal cooked, I'm going to raise the roof; and if she does, I'm not going to eat a bite." (4) Some people are against everything. A man went in late at a business meeting of the church. As he sat down he said, "I don't know what you are talking about, but I'm against it."

6. The Christian has a *grateful* disposition. (1) Col. 3:15. (2) Only one of the ten lepers returned to thank

Jesus (Lk. 17:12-19). (3) Ingratitude is one of the most despicable traits. Some people find it hard to say, "I thank you." (4) A good memory will help you to be grateful. Count your blessings.

7. The Christian personality is *easily entreated* — not stubborn or self-willed. (1) Jas. 3:17. (2) This is a qualification for an elder (Tit. 1:7). (3) A man once said that a horse was seventeen feet high. The other man replied, "You mean seventeen hands high, don't you?" He replied, "Well, what did I say?" The answer: "You said 'Seventeen feet high'." He continued, "Well, if I said seventeen feet high, I will stick with it. That horse was seventeen feet high."

8. The Christian's disposition is *tolerant* — no mote-hunter. (1) Some people develop eyestrain looking for the faults of others. (2) The worst fault is the inability to see our own mistakes. Man said, "I think I could see my faults, if I had any."

9. *Fairness* is a required trait of the Christian disposition. (1) Golden Rule demands it (Matt. 7:12). (2) Some people have one rule for you and another for themselves. (3) Unselfishness is essential to fairness (Phil. 2:4).

10. The Christian must be *courageous*. (1) It takes more courage to be a Christian than it does to be anything else. (2) Must stand for something (Jude 3). We cannot stand for something without standing against something (Psa. 97:10; 119:104).

IS ONE CHURCH AS GOOD AS ANOTHER?

1. *Introduction*. If you are seeking a companion for life, is one as good as another? If you are catching a train, is one as good as another? If you need a physician, is one as good as another? If you need medicine, is one as good as another? If you are computing figures, is one as good as another? If you are making an investment, is one as good as another? Why be so careful in material

matters and so careless in spiritual matters? So we ask: Is one church as good as another?

2. *Not unless one God is as good as another*, because different religions have different gods — Buddhism, Shintoism, etc. But there is “one God and Father of all” (Eph. 4:6). Matt. 4:10.

3. *Not if we have to believe in Christ* as the only begotten Son of God, because some churches do and others do not. But faith in the Sonship of Christ is not an optional thing (Jno. 8:24).

4. *Not unless one founder is as good as another*, because different churches have been founded by different individuals. The church of the Bible was founded by Christ (Matt. 16:18). The church founded by Christ is surely better than one founded by man (Matt. 15:13).

5. *Not unless the blood of Christ is unimportant*, because Christ’s church cost his blood (Acts 20:28). The church purchased by the blood of Christ is better than one which cost Christ nothing.

6. *Not unless the churches not mentioned in the Bible are as good as the one spoken of in the Bible*. Christ’s church is mentioned in the Bible (Matt. 16:18). Various congregations of the Lord’s church are spoken of in Rom. 16:16. Churches not mentioned in the Bible surely are not as good as the one that is mentioned.

7. *Not unless one head is as good as another*, because different churches have different heads. Christ is the head of the church mentioned in the Bible (Eph. 1:22,23; 5:23). The church which has Christ as its only head is unquestionably better than a church with a human head.

8. *Not unless one foundation is as good as another*, because different churches have been founded upon different foundations. Christ’s church was founded upon the glorious truth that he is the Son of God (Matt. 16:16-18; I Cor. 3:11; Eph. 2:20). The church founded upon Christ is unmistakably better than one founded upon man.

9. *Not if worship is important*, because different churches have different kinds of worship. One worship

is not as good as another (Jno. 4:23,24; Matt. 15:9); therefore, one church is not as good as another.

10. *Not unless one doctrine is as good as another*, because different churches preach different doctrines. But one doctrine is not as good as another (Gal. 1:7-9; II Jno. 9-11); therefore, one church is not as good as another.

11. *Not unless one way is as good as another*, because different churches travel different ways. The broad way is not as good as the narrow way (Matt. 7:13,14). He who climbs up some other way is a thief and a robber (Jno. 10:1).

12. *Not unless one creed is as good as another*, because different churches have different creeds. The church of the Bible has the Bible as its only creed (II Tim. 3:16,17); and that is surely better than any human creed.

13. *Not unless one baptism is as good as another*, because different churches teach and administer different baptisms. There is only one baptism to be obeyed today — baptism of the Great Commission (Matt. 28:19,20; Eph. 4:5) — and the church which preaches this is surely better than one which preaches something else.

14. *Not unless one name is as good as another*, because different churches have different names. The members of Christ's church wore the name Christian (Acts 11:26; I Pet. 4:16). We insist that this name is better than a human name. Thus, one church is not as good as another.

HOW TO FIGHT SATAN

1. *Watch and pray* (Matt. 26:41).
2. *Quote Scriptures* to him as Jesus did (Matt. 4:1-11).
3. *Put on the whole armor of God* (Eph. 6:11).
4. *Learn Satan's devices* lest he get the advantage (II Cor. 2:11). (1) He comes clothed in the robes of: A. Pleasure (Jas. 4:4; Lk. 8:14). B. Business (Matt. 13:22). C. Worldly things (I Jno. 2:15-17). D. Righteousness and religion (II Cor. 11:14,15). (2) Satan blinds the minds

of men through (II Cor. 4:4): A. Prejudice (Matt. 13:15; Acts 7:57). B. Party spirit (Acts 13:45,46). C. Lack of knowledge (Hos. 4:6; Jno. 8:32). D. Procrastination (Acts 24:25). (3) Satan persecutes (Rev. 2:9,10; II Tim. 3:12).

5. "*Neither give place to the devil*" (Eph. 4:27). Stand (Eph. 6:13).

6. *Resist the devil* — draw nigh to God (Jas. 4:7,8).

THE WAY HOME

1. *This earth is not our home.* We are just passing through to another land. (1) Eccl. 12:5; II Cor. 5:1; Jno. 14:1-4. (2) Song: "Guide me, O thou great Jehovah, pilgrim through this barren land." (3) There is one of two places to go after death (Matt. 25:46).

2. *To go home to heaven, one must desire it.* (1) Abraham did (Heb. 11:10). (2) David did (II Sam. 12:23). (3) Paul did (Phil. 1:23,24).

3. *To go home to heaven, one must decide to go.* (1) Life is filled with decisions. (2) Cannot have everything — must decide what we shall have. A decision not to go to heaven is actually a decision to go to hell. (3) God, Christ, and Holy Spirit plead with us to make the right decision (Rom. 10:21; II Pet. 3:9; Rev. 22:17). (4) This is a personal thing — no one can decide for you, live for you, or prepare for you. The five wise virgins could not divide their oil with the five foolish ones (Matt. 25:1-12).

4. *One way to God* (Jno. 14:6). (1) Christ, the one way, has given one body (Eph. 4:4), one faith (Eph. 4:5), one Bible (II Tim. 3:16,17), one mediator (I Tim. 2:5), and one rule (Phil. 3:16). (2) Narrow way (Matt. 7:13,14). Narrowness does not make a road bad; for instance, railroad. (3) One way is not as good as another (Prov. 14:12).

5. *The way is simple* (Isa. 35:8). There are three steps: (1) Out of self (Matt. 16:24; Matt. 18:8,9). (2) Into Christ. Baptized into Christ (Rom. 6:3,4). Baptism must be preceded by faith, repentance, and confession. All

spiritual blessings are in Christ (Eph. 1:3). The person in Christ must abide in him (Jno. 15:6), add to the faith (II Pet. 1:5-10), walk after the Spirit (Rom. 8:1), and persevere (Matt. 10:22). (3) Into heaven. This is the journey's destination (Matt. 25:34).